

RADIO CONTROLLED ELECTRIC POWERED RACING BUGGY  
**OFF-ROAD RACER**

# MAXXUM FF

- FRONT WHEEL DRIVE. FRONT MOTOR/MID BATTERY FOR PERFECT BALANCE.
- HEIGHT ADJUSTER/TRAVEL LIMITER ON FRONT.
- REAR SUSPENSION. FULL CAMBER/TOE-IN ADJUSTMENT.
- OIL-FILLED SHOCK ABSORBERS ON ALL WHEELS.
- 17S ALLOY ALUMINUM CHASSIS/FRP UPPER PLATE.
- FRONT-MOUNTED MOTOR (INCLUDED) FOR DIRECT DRIVE AND BEST BALANCE. POWERFUL LEMANS 240ST MOTOR INCLUDED.
- HIGH-QUALITY ROTARY SPEED CONTROLLER (INCLUDED).
- 7.2V-1200mAh NiCd BATTERY AND TWO CHANNEL RADIO (NOT INCLUDED).

1:10 SCALE



**KYOSHO**  
THE FINEST RADIO CONTROL MODELS

KIT NO.3127

# BEFORE YOU BEGIN ASSEMBLY!

Thank you for purchasing the Kyosho's R/C "Off-Road Racer Maxxum FF".

In order to keep your Maxxum FF in the tip top condition to enjoy the most pleasure from the R/C world, you should thoroughly read through this instruction manual and the operation instruction of the radio control units to keep the correct way of assembling, and handling.

## [Features of the Kit]

- It is a front wheel drive type, and the car shows excellent running capability on a slippery or bumpy road, also boasting superb straight going trait.
- The front suspension with an extra long arm will absorb shocks from the potholed road surface. The rear suspension with a linked extraordinary shaped double wishbone will make you to adjust the camber toe-in/out setting easily.
- We have taken front midship style for motor mounting which motor is located right behind the front wheels. So, though even it is front wheel driven, the car has a quick response to the steering control, at the same time, allowing to design the body in a very slim shape. It is the first Kyosho's fullfledged FF off-road racing car.

## CONTENTS

BEFORE YOU BEGIN ASSEMBLY	2	23 INSTALLATION OF MOTOR	15
BEFORE ASSEMBLY	3	24 INSTALLATION OF GEAR COVER	16
LIST OF BAGGED PARTS (1)	4	25 INSTALLATION OF TIRE	16
LIST OF BAGGED PARTS (2)	5	● INSTALLATION OF RADIO UNIT • LINKAGE	
LAYOUT DRAWING OF PLASTIC PARTS ON RUNNERS.	6	26 - 34	
● ASSEMBLY OF CHASSIS PORTION 10 - 25		26 HOW TO CHECK RADIO UNIT	16
1 ASSEMBLY OF OIL SHOCK	7	27 INSTALLATION OF SERVO	17
2 FILLING THE SHOCK OIL	7	28 ASSEMBLY OF SERVO SAVER	17
3 SCREW IN THE BALL END	8	29 STEERING LINKAGE	17
4 INSTALLATION OF TIE ROD JOINT & REAR SUSPENSION ARM (B)	8	30 INSTALLATION OF RESISTOR & SWITCH	18
5 INSTALLATION MAIN CHASSIS	8	31 INSTALLATION OF SPEED CONTROLLER	18
6 INSTALLATION OF RADIO PLATE	9	32 INSTALLATION OF RECEIVER	18
7 ASSEMBLY & INSTALLATION OF REAR SUSPENSION ARM (A)	9	33 SPEED CONTROLLER LINKAGE	19
8 ASSEMBLY OF REAR HUB	10	34 INSTALLATION OF NI-CD BATTERY	19
9 INSTALLATION OF REAR HUB	10	● CUTTING & MOUNTING OF BODY	
10 INSTALLATION OF REAR SHOCK & REAR TIE ROD	10	35 CUTTING OF BODY	20
11 ASSEMBLY OF DIFFERENTIAL GEAR	11	36 PAINTING	20
12 INSTALLATION OF JOINT	11	37 ASSEMBLY OF BODY & APPLYING OF DECAL	20
13 CUTTING OF GEAR COVER	12	38 MOUNTING OF BODY	21
14 INSTALLATION OF COUNTER GEAR & FINAL PINION GEAR	12	CHECKING AND MAINTENANCE OF ROTARY SPEED CONTROLLER	21
15 ASSEMBLY OF GEARBOX	12	SETTING GUIDE (1)	21
16 INSTALLATION OF FRONT SHOCK STAY	13	SETTING GUIDE (2)	22
17 INSTALLATION OF KNUCKLE ARM	13	PARTS LIST	22
18 INSTALLATION OF FRONT SUS. ARM	13	PURCHASABLE PARTS FOR YOUR KIT	23
19 INSTALLATION OF GEARBOX & BUMPER	14	EXPLODED VIEW	24
20 INSTALLATION OF ROD PARTS (FRONT PORTION)	14	"	25
21 INSTALLTION OF FRONT SHOCK	15		
22 INSTALLATION OF CENTER GEAR	15		

# BEFORE ASSEMBLY

Read the instruction carefully

You can assemble the kit more easily if you have grasped the general idea of reading it through to the end.

\*Check the parts in the kit.

Check to see if all the parts are correctly bagged as they are listed in the "List of Bagged Parts". Your thorough understanding of the assembly prior to starting will enable you to build the kit without difficulty.



Any claims for replacements or refunds for the model in the process of assembly will not be accepted without shortage or inferiority of the parts.

\*Learn on the marks described in the instruction.

**LOCKTITE** ... Places to put some locktite. (It will prevent the screws and nuts get loosen by vibration while running.)

**GREASE** ... The place where grease should be applied. (It will reduce friction to assure smooth movements.)



Steps where your particular attention is required.

\*Be well aware of the different types of screws.

1. The difference between the TP screw (short form of self-tapping screw) and the ordinary screw is...

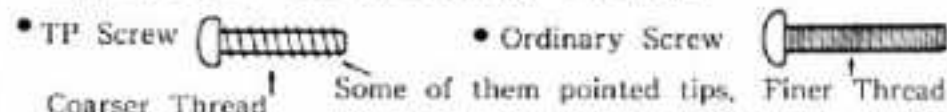

2. The kinds of screws which will be used in this instruction.

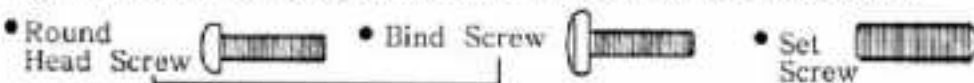

There are two kinds of thread, finer and coarser ones.

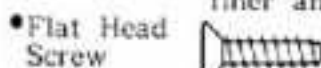

\*Pick up the correct parts and screws. Compare the shape and size of small parts, such as screws, nuts, and washers with the attached sheet of "List of Small Parts".

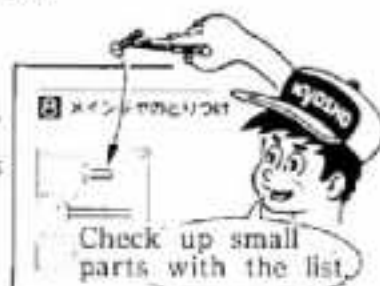

\*Be sure about the location and direction of parts to install.

Double-check the location and orientation of parts with the illustration before installation. When necessary, assemble the parts themselves tentatively before proceeding to the next step.



\*Do not tighten the TP screw too strong.

Do not use excessive force when tightening the TP screws, or you may strip the thread in the plastic. It is recommended to stop tightening it when the thread part on the screw goes into the plastic part and you feel some resistance from the tightening.

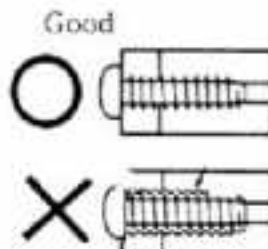

Over tighten may strip the thread in the plastic.

## THINGS NEED BESIDES THE KIT [2 Channel Radio System]



This model is designed for being controlled by a BEC type radio only. Get a radio with a mark as shown at left.

Two types of radio control set are on the market, the stick type and the steering wheel type. Choose which ever you like.

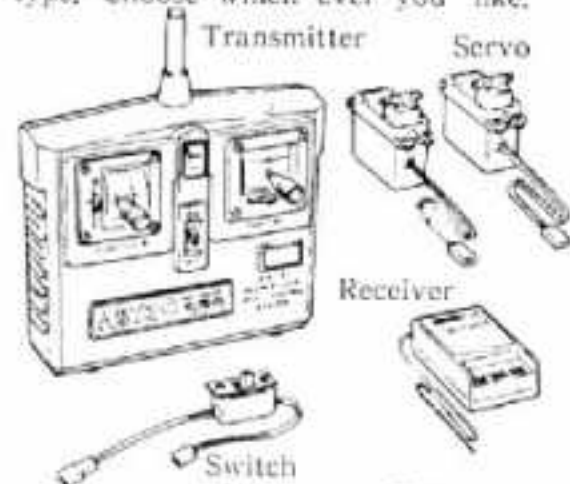

[Battery for Radio System]  
AA Size Battery For Transmitter...8 pcs.

## [Ni-Cd Battery]



7.2V Sprint Battery SCR 7.2V Racing Battery

## [Motor]

Kit includes, Le Mans 240ST. Also following Kyosho motors are available in the line in your favor.

- No.1986 Le Mans Speed 240T
- No.1925 Le Mans 360G
- No.1926 Le Mans Sports II-240S
- No.W1011 SPA 240WS

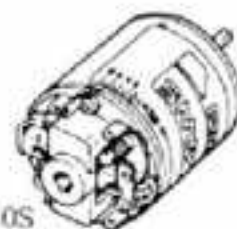

Use one of the chargers listed below which suits your need

Model	Name	Time	Rate%	Features
No.2221	Super NiCd Charger (AC100V)	14 to 16hrs.	100%	For beginners
No.2326	7.2V Power Quick Charger (DC12V)	15 min.	about 70%	For beginners Built-in timer
No.1849	Multi Charger II (DC12V)	20 min.	100%	Timer, Ammeter built in
No.1845	Delta Peak Charger (DC12V)	about 20 min.	100%	Ammeter in, Automatic cut-off at peak of charge
No.2232	Super NiCd AC Rapid Charger	about 40 min.	about 80%	Chargable from Household outlet. Electronic timer built in

[Required Tools] Hex. key, grease, CW cement are included with the kit.  
Philips Screw Driver (L,M,S)  
Slot Screw Driver (M)

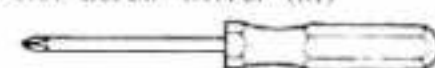

Box Driver (for M3 & M4 Nut)

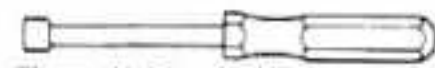

Sharp Hobby Knife



Needle Nose Plier



Round Cutter



Sander



Awl



Wire Cutter



Instant Glue



Polyca Paint



Brush



Micron Line Tape



**LIST OF BAGGED PARTS (1)** The key numbers with \* indicatd plastic parts on a runner. See page 6 for the layout drawing.

[Do not throw away a bag header]

- The symbol in the brackets after a name of parts in this instruction is the header number in which the part is contained.
- The header is the only thing to rely upon when looking for a part. Do not discard it until you finish the assembly.



Bag	Key #	Parts Name	Q'ty	Step
Blister	1	Main Chassis	1	1
	2	Knuckle Arm (R)	1	2
	3	Knuckle Arm (L)	1	3
	4	Center Gear	1	4
	5	Counter Gear	1	5
	6	Final Pinion	1	6
	7	Pinion Gear (15T)	1	7
	8	Front Drive Washer	2	8
	9	Joint	2	9
	10	Le Mans 240ST Motor	1	10
	11	Swing Shaft	2	11
	12	Front Wheel Shaft	2	12
	13	Rotary Speed Controller	1	13
	14	Resistor	1	14
	15	Resistor Cover	1	15
	16	Motor Plate	1	16
	17	Front Shock Spring	2	17
	18	Rear Shock Spring	2	18
① For Front	19	Front Shock Case	2	19
	20	Front Shock Shaft	2	20
	21	Pressure Top	2	21
	22	Shock Ring	2	22
	23	E Ring (E2.5)	4	23
	24	Shock End	2	24
	★25	Spring Spacer	2	25
	★26	Spring Holder	2	26
	★27	Shock Cap	2	27
	★28	Shock Piston	2	28
MX-2	29	Rear Shock Case	2	29
	30	Rear Shock Shaft	2	30
	21	Pressure Top	2	21
	22	Shock Ring	2	22
	23	E Ring (E2.5)	4	23
	24	Shock End	2	24
	★25	Spring Spacer	2	25
	★26	Spring Holder	2	26
② For Rear	★27	Shock Cap	2	27
	★28	Shock Piston	2	28

Bag	Key #	Parts Name	Q'ty	Step
MX-2	31	Shock Oil (Green)	1	31
MX-3	32	Wheel	4	32
MX-4	33	Rear Wheel Shaft	2	33
	34	Arm bush (A)	2	34
	35	Arm Bush (B)	2	35
	36	King Pin	4	36
	37	2 φ x11 Pin	4	37
	38	Center Gear Shaft	1	38
	39	Counter Gear Shaft	1	39
	40	Bevel Shaft	1	40
	41	Bevel Gear (A)	2	41
	42	Bevel Gear (B)	2	42
	43	Main Gear	1	43
	44	Differential Case	1	44
	45	O Ring (P3)	1	45
	46	8 φ Plane Bearing Collar	2	46
	47	4 φ X 8 Plane Bearing	1	47
	48	5 φ X10. Plane Bearing	10	48
	49	10 φ X14. Plane Bearing	2	49
MX-5	50	Tie Rod Joint	1	50
	51	Torque Rod	1	51
	52	Suspension Plate	1	52
	53	Upper Deck	1	53
	54	Steering Rod	1	54
	55	Speed Controller Rod	1	55
	56	Gear Cover	1	56
	57	Motor Cord	1	57
	58	Double Sided Tape	1	58
	59	Strap (S)	3	59
	60	Ni-Cd Strap	2	60
MX-6	61	Antenna Pipe	1	61
	62	Resistor Bracket	1	62
	126	Condenser	1	126
	★63	Front Hub	2	63
	★64	Stabilizer End	2	64
	★65	Front Suspension Arm	2	65
	66	Gearbox (R)	1	66
67	Gearbox (L)	1	67	

LIST OF BAGGED PARTS (2)

Bag	key #	Parts Name	Qty	Step
MX-6	★68	Rear Suspension Arm (A)	2	■
	★69	Rear Suspension Arm (B)	2	■
	★70	Suspension Arm Bracket	2	■
	★71	Rear Shock Stay (B)	2	■
	★72	Suspension Arm End	2	■
	★73	5.8 φ Ball End (M)	2	■
	★74	5.8 φ Ball End (L)	2	■
	★75	Rear Hub	2	■
	★76	Servo Mount	2	■
	★77	Joint Arm (A)	1	■
	★78	Joint Arm (B)	1	■
	★79	Saver Washer	1	■
	★80	Speed Controller Arm	1	■
	★81	Shock Bush	4	■ ■
	★82	Servo Stay (A)	2	■
	★83	M4 Plastic Nut	4	■
	★84	M3 Plastic Nut	6	■ ■
	★85	Shock Spacer	4	■
	★86	Servo Saver	1	■
	★87	Saver Ring	1	■
	★88	Saver Horn (F)	1	■
	★89	Saver Horn (LS)	1	■
	★90	Saver Horn (SS)	1	■
	★91	Gearbox Hatch	1	■
	★92	Rear Driver Washer	2	■
	★93	Front Shock Stay	1	■
	★94	Rear Shock Stay (A)	1	■
	★95	Body Mount	1	■
	★96	Switch Holder	1	■
	★97	Resistor Mount	1	■
	★98	Wing Collar	4	■
	★99	Bulk Head	1	■
	★100	Servo Stay (B)	1	■
★101	Bumper	1	■	
★102	Bumper Arm	1	■	
★103	Upper Deck Mount	1	■	
MX-7	104	Linkage Collar	2	■
	105	Suspension Shaft (S)	2	■
	106	Suspension Shaft (M)	2	■
	107	Suspension Shaft (L)	2	■
	108	Front Tie Rod	2	■
	109	Upper Rod	2	■
	110	Rear Tie Rod	2	■
	111	5.8 φ Ball End (S)	8	■

Bag	Key #	Parts Name	Qty	Step
MX-7	112	4.8 φ Ball End	1	■
	113	M2.6 Pillow Ball (Black)	6	■ ■ ■
	114	Pivot	2	■
	115	6.8 φ Ball	6	■ ■
	116	5.8 φ Ball	10	■ ■
	117	4.8 φ Ball	1	■
	118	Battery Holder	2	■
		119	Body	1
120		Tire	4	■
121		Decal	1	■
		Instruction	1	
MX-1	23	E Ring (E2.5)	11	■ ■
	122	E Ring (E3) (Black)	2	■
	123	E Ring (E4)	4	■ ■
	124	Hook Pin	1	■
	125	Body Pin	2	■
		Hex Key (1.5)	1	
		Hex key (2)	1	
		Bind Screw M3 X 6	7	
		• M3 X 18	4	
		• M3 X 30	2	
		• M3 X 35	2	
		Round Head Screw M2 X 4	1	
		• M3 X 10	4	
		TP Bind Screw M2.6 X 6	1	
		• M2.6 X 12	6	
		• M3 X 10	41	
		TP Round Head Screw M2 X 10	4	
		• M2 X 12	1	
		• M3 X 18	4	
		TP Flat Head Screw M3 X 15	18	
		Nut M2.6	4	
		• M3	6	
		Flange Nut M3	2	
		Nylon Nut M4	2	
		Washer M2.6 X 7	1	
	• M4 X 10	2		
	• M5 X 12	2		
	Set Screw M3 X 3	1		
	• M4 X 4	3		
	• M4 X 8	2		
	• M4 X 15	2		

# LAYOUT DRAWING OF PLASTIC PARTS ON RUNNERS

(When cutting off parts from a runner...) \*pay particular attention when detaching the piston.

Cut it off with a dike.

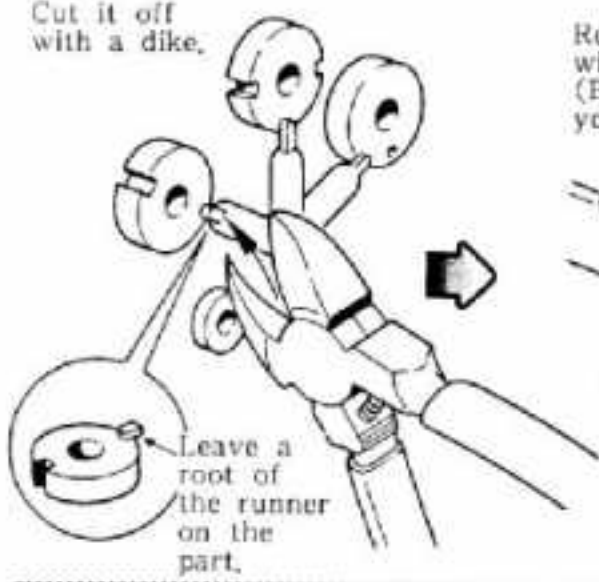

Remove the stubble with a hobby cutter. (Be careful not to cut your finger)

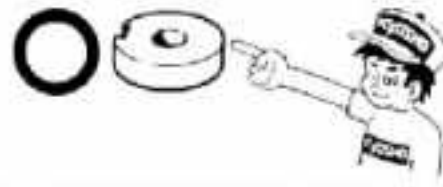
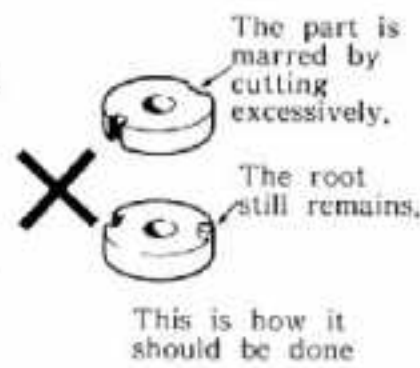
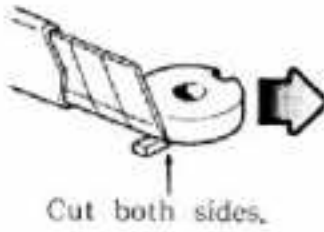

Shock Parts

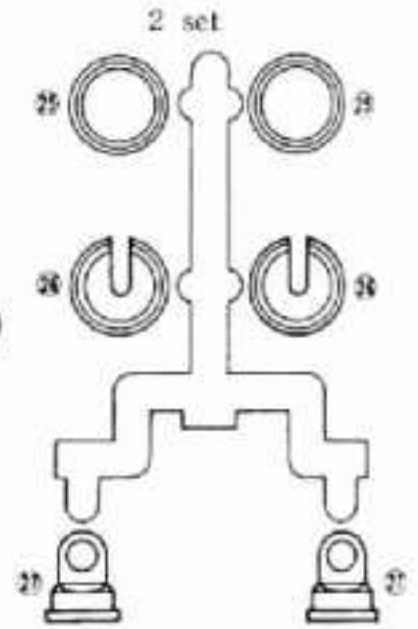
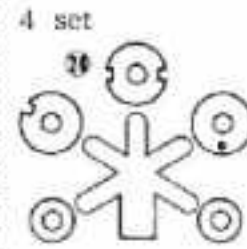

FRONT SUSPENSION ARM 2 set

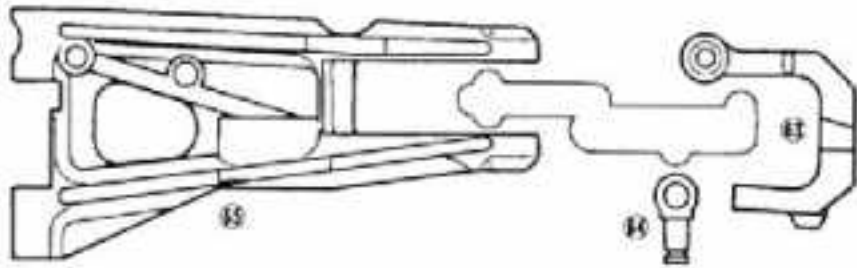

REAR SUSPENSION ARM PARTS, ETC. 2 set

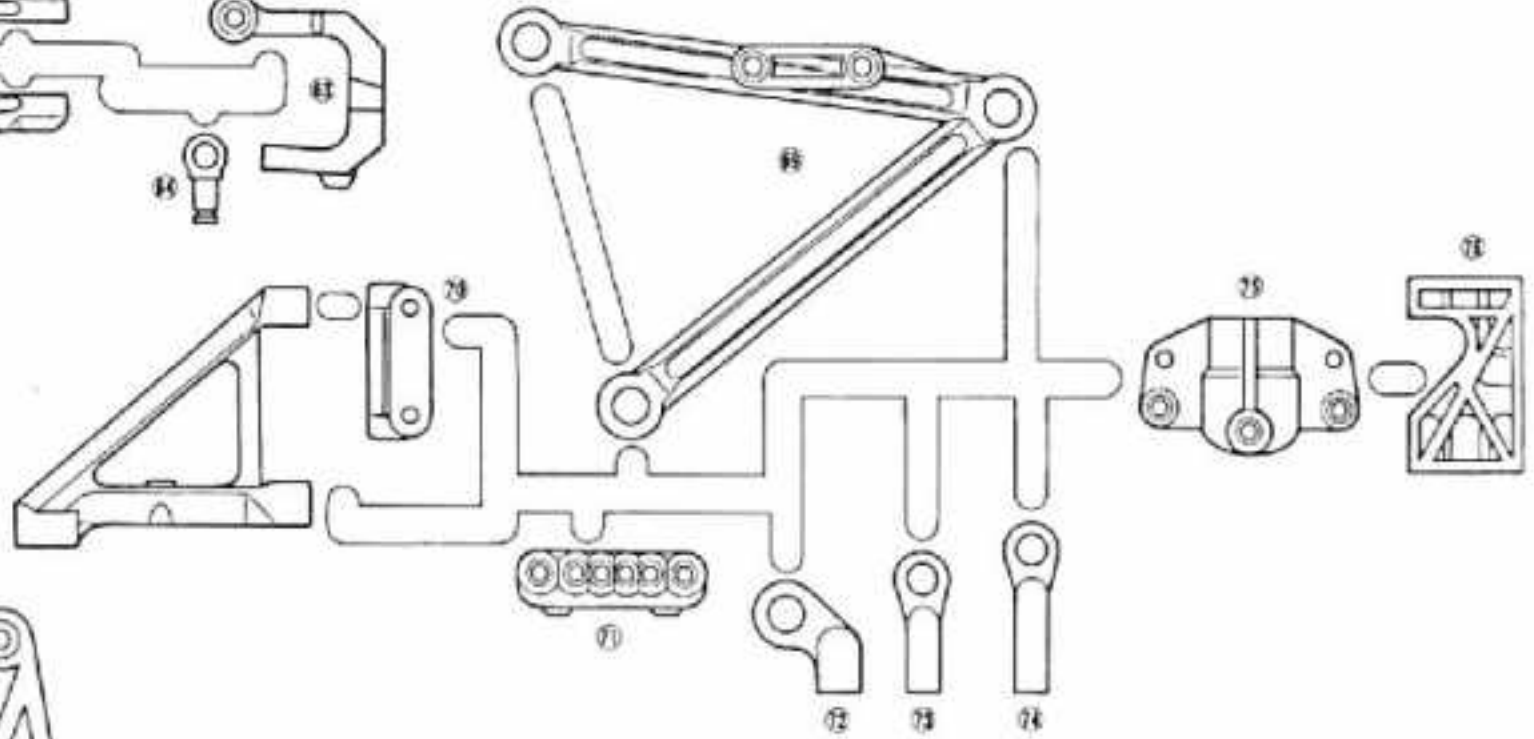

SHOCK STAY PARTS 1 set

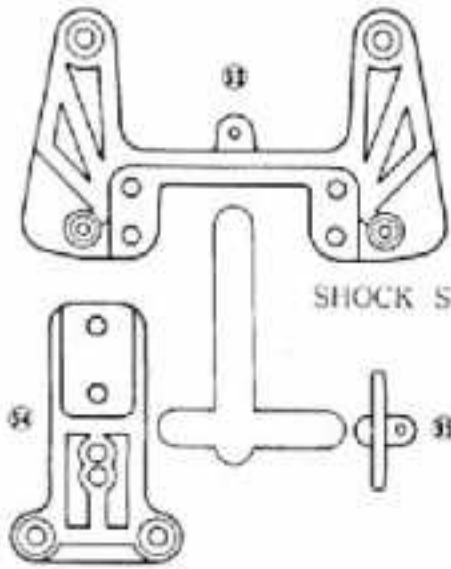

BUMPER PARTS, ETC. 1 set

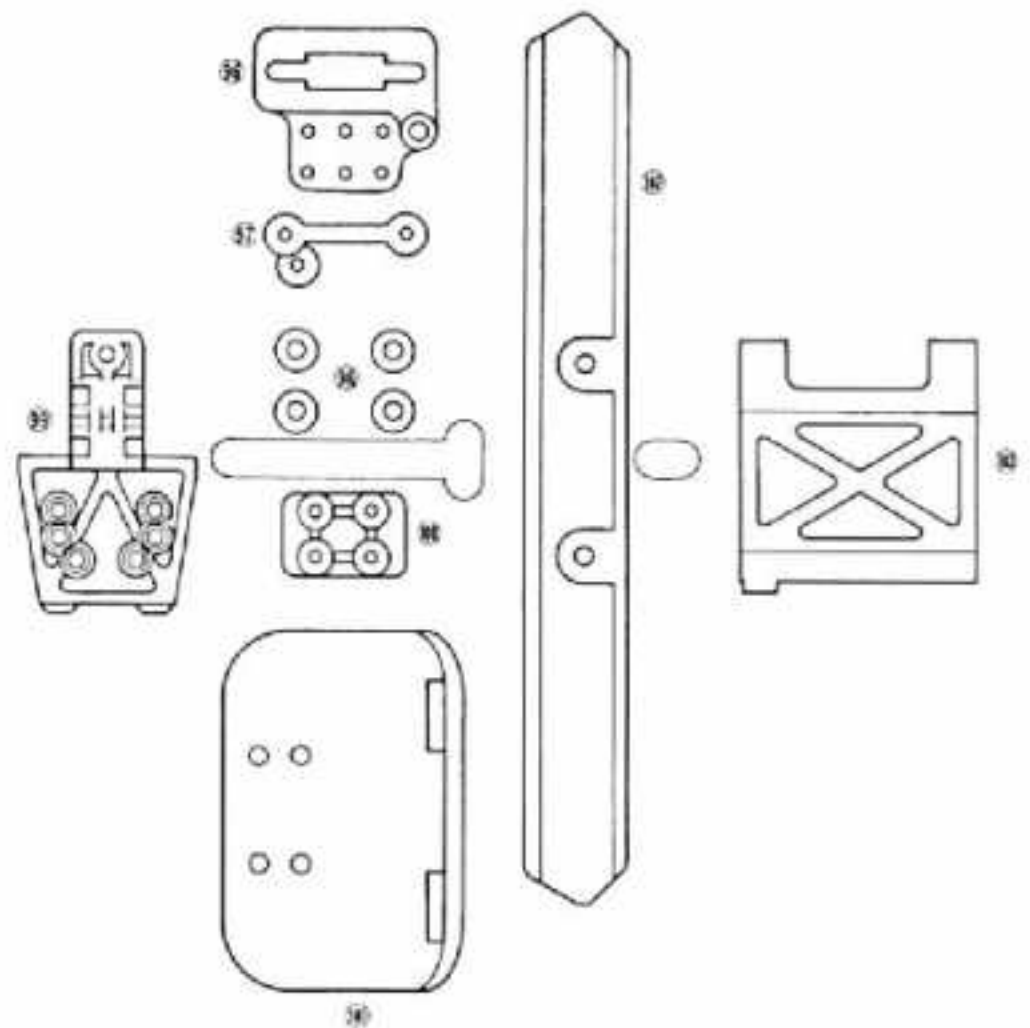

SERVO SAVER PARTS, ETC. 1 set

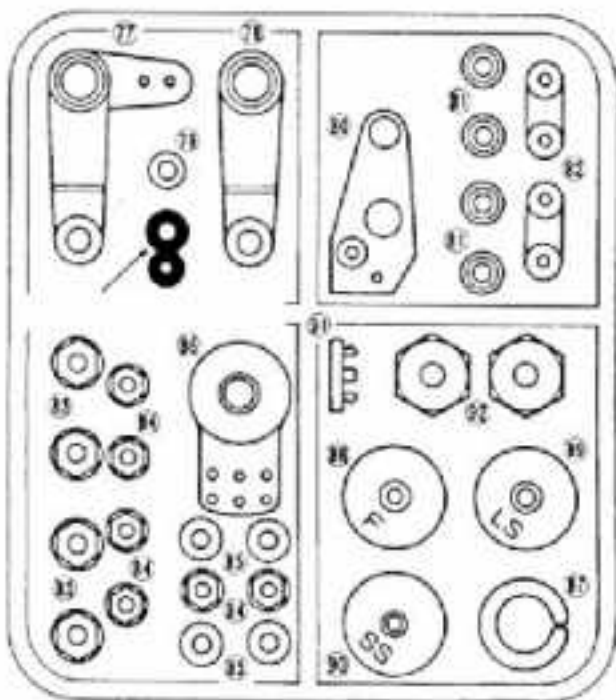

# 1 ASSEMBLY OF OIL SHOCK

Two each of this parts in 16 and 31, 4 pieces in total, will be used.

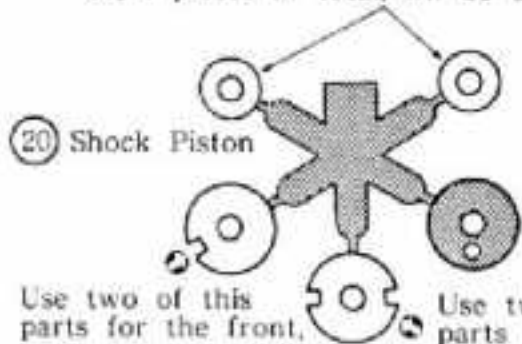

Some small parts are shown, enclosed in a frame as below, in the life size. Pick up the parts from the bag and identify them with the picture.

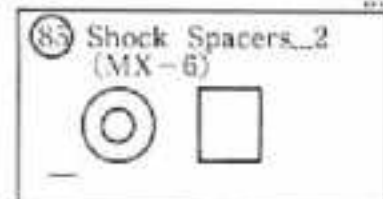

## Stage 1

Shock Piston (For rear)

37 Rear Shock Shaft (Longer one)

25 E Ring (E2,5)

29 Rear Shock Case (Longer one)

The front shock parts are contained in the bag (MX-1) 1, and the rear parts in the bag (MX-1) 2.

[For the front portion]

## Stage 1

Shock Piston (For front)

E Ring (E2,5)

19 Front Shock Case (Shorter one)

20 Front Shock Shaft (Shorter one)

## Stage 2

24 Shock End

Cushion to avoid damage to the shaft.

\* Assemble two of this.

## Stage 2

24 Shock End

\* Assemble two of this.

85 Shock Spacer

Use the spacer only for the rear shock.

## OPTION W-5002

Put a spacer for the optional pressure shock (L), too.

# 2 FILLING OF SHOCK OIL

Stage 1 Move the piston to the bottom and pour oil slowly. Move the piston up and down gently to get rid of air bubbles.

The front shock parts are contained in the bag (MX-1) 1, and the rear parts in the bag (MX-1) 2.

Stage 2 With the piston down to the bottom, tighten the shock head gently. Then the excessive oil may flow out.

Stage 3 Move the piston up and down checking to see if it operates smoothly.

Fit the case with oil a little over the brim.

31 Shock Oil (Green)

[Assembly of Shock Head]

21 Pressure Top

20 Shock Cap

22 Shock Ring

Tighten the head firmly to avoid the oil leaking.

It should slide smoothly.

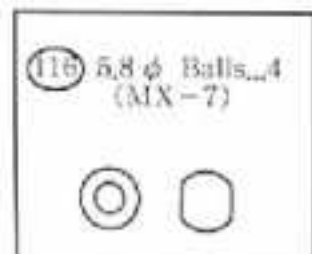

Use the spring spacer only for the front shockers.



25 Spring Spacer

17 Front Shock Spring (Blister)

18 Rear Shock Spring (Blister)

Stage 4 Fix the other parts to complete the assembly.

26 Spring Holder

Install the front shock in step 21, and the rear ones in step 10.

Compress the spring.

### 3 SCREW IN THE BALL END

Screw in the ball ends, identifying the length with the life-size drawing. Two rods of each size are required.

[Actual Size]

- [MX-6]
  - 72 5.8 φ Ball Ends (L)...2
  - 73 5.8 φ Ball Ends (M)...2
  - [MX-7]
  - 111 5.7 φ Ball Ends...8
  - 108 Front Tie Rods...2
  - 109 Upper Rods...2
  - 116 5.8 φ Balls...6
  - 110 Rear Tie rods...2
- \*This rod is used as 108 and 109 in common.

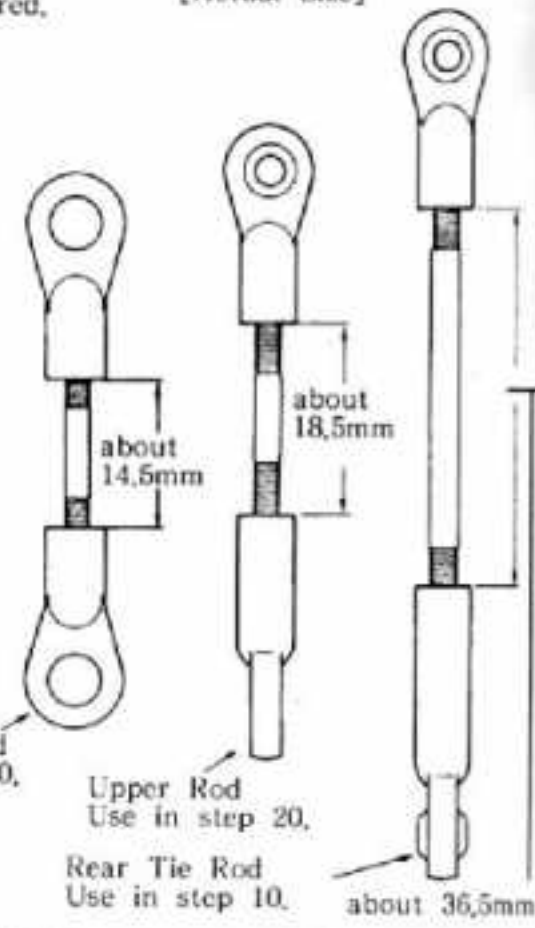
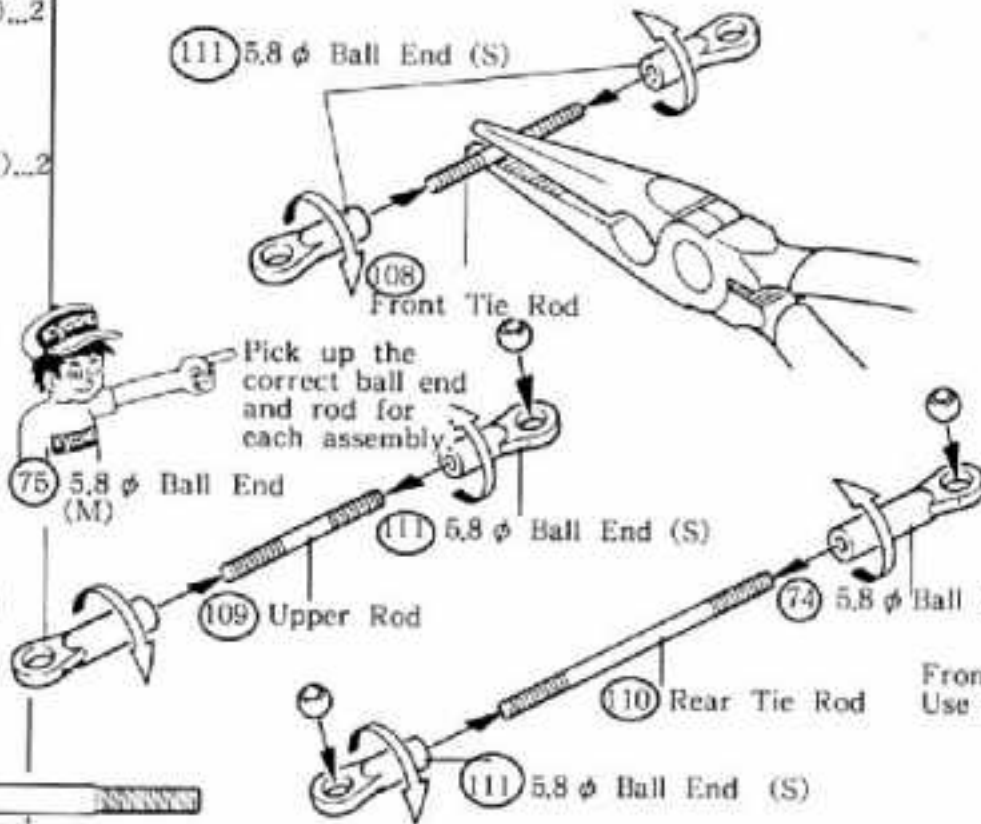

### 4 INSTALLATION OF TIE ROD JOINT AND REAR SUSPENSION ARM (B)

- M3x15 TP Flat Head Screws...4
- M2,6 Nuts...6
- [MX-7]
- 113 M2,6 Pillow Balls (Black)...2
- 115 6.8 φ Balls...4

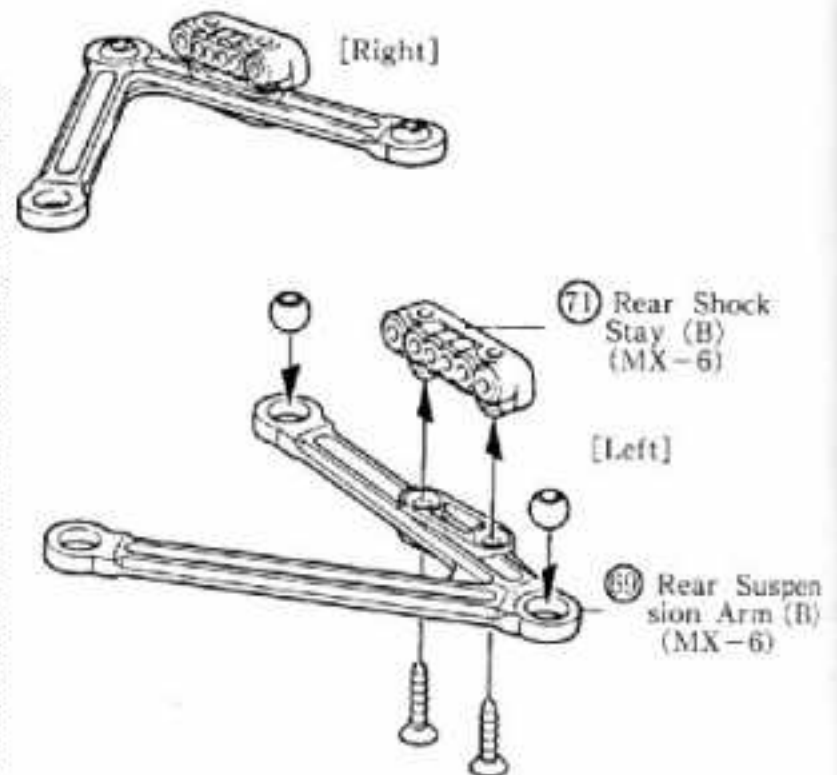
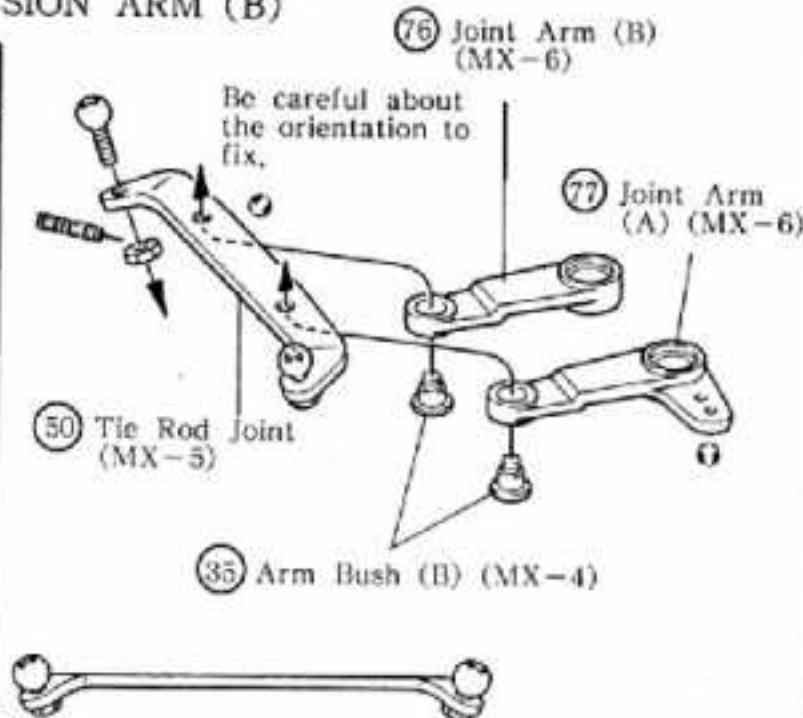

### 5 INSTALLATION OF MAIN CHASSIS

- M3x6 Bind Screws...4
- M3x10 TP Bind Screws...4
- M3x18 TP Round Head Screws...2

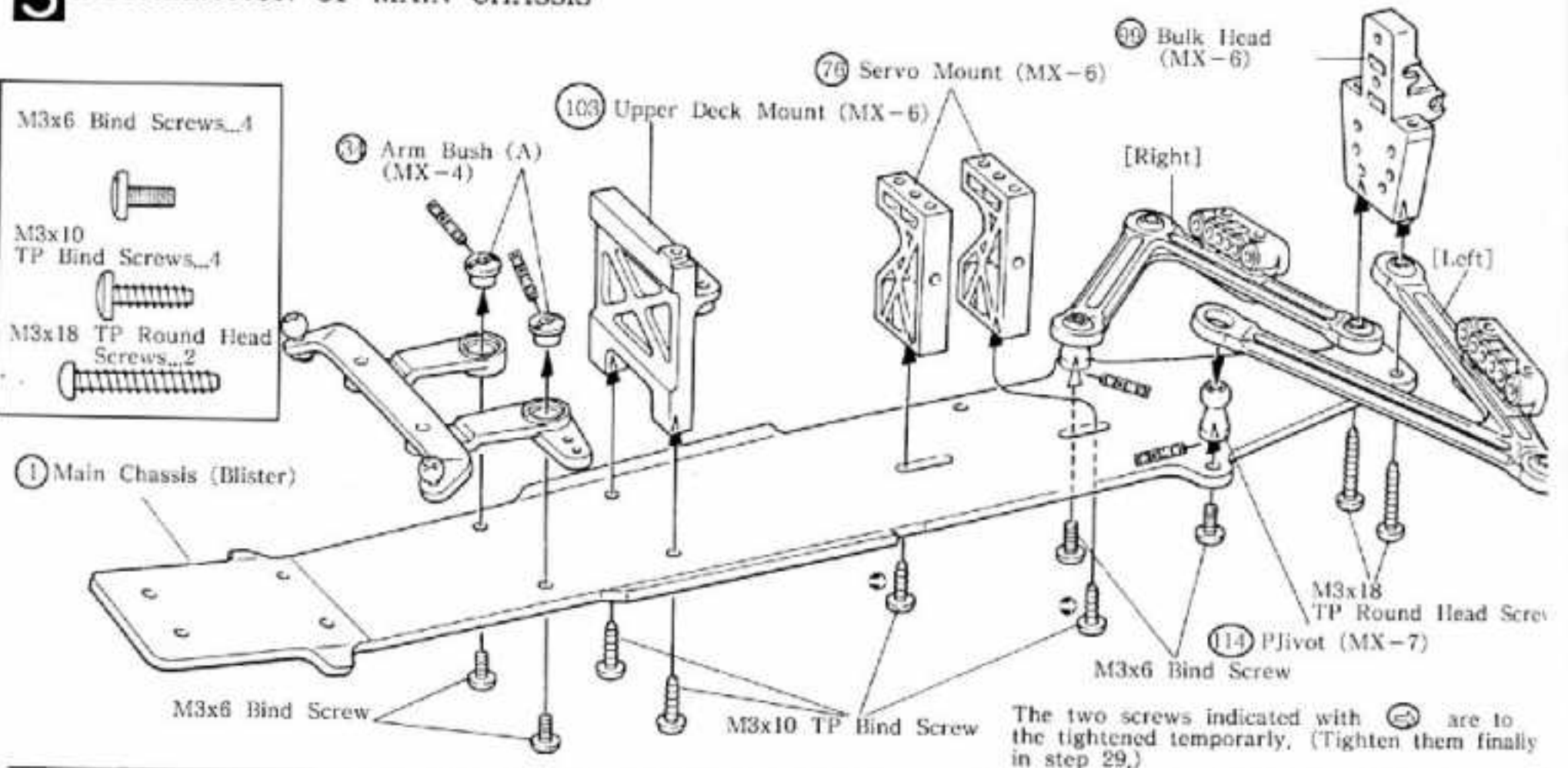



## 6 INSTALLATION OF RADIO PLATE

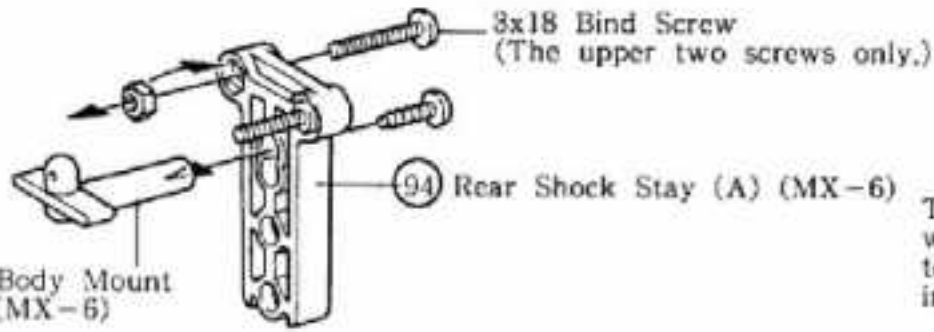

### Stage 2

The two screws indicated with ⇨ are to be tightened temporarily. (Tighten them finally in step 29)

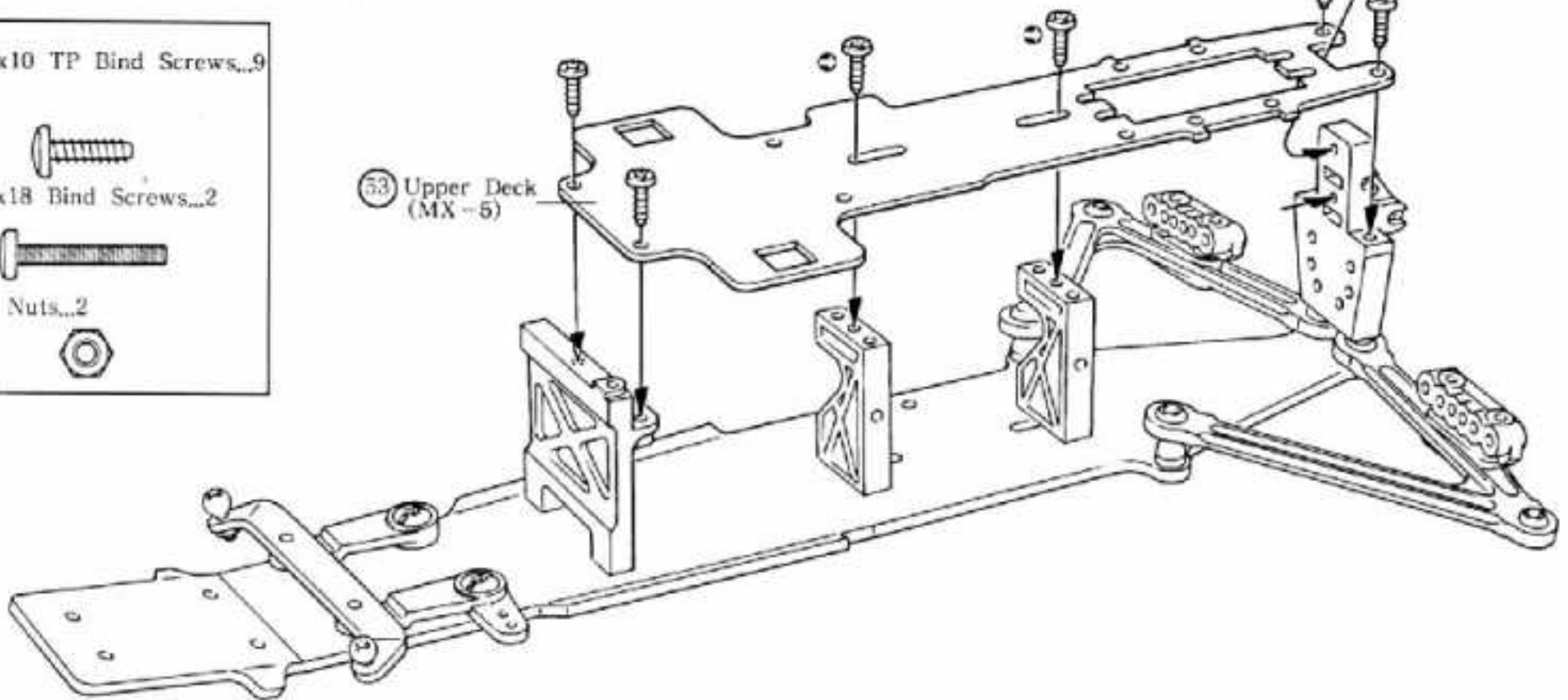

## 7 ASSEMBLY AND INSTALLATION OF REAR SUSPENSION ARM (A)

### Stage 1 [Left]

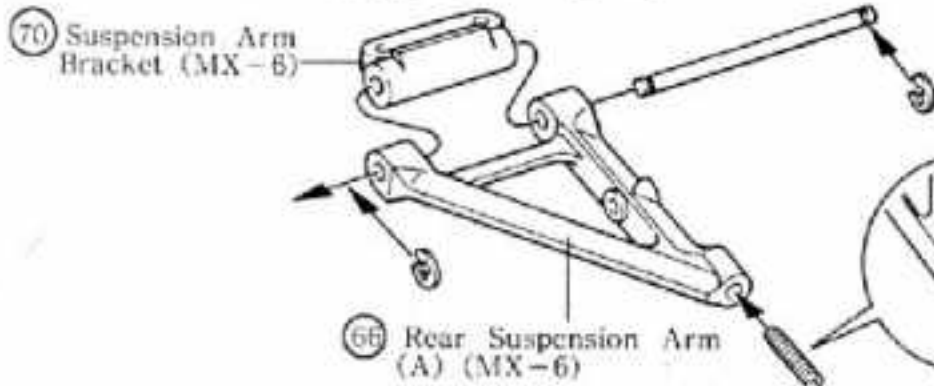

### Stage 2

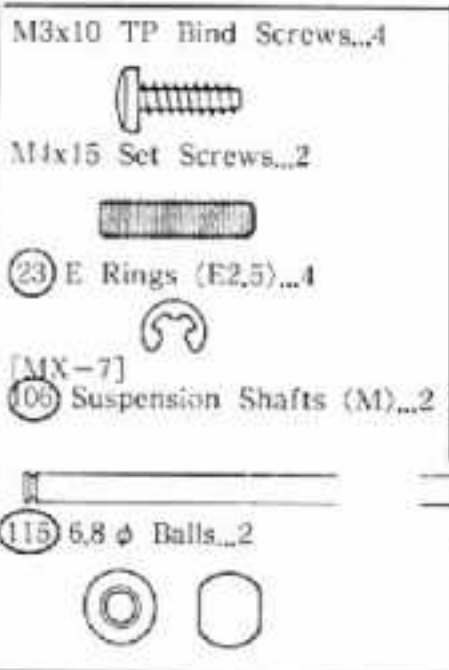
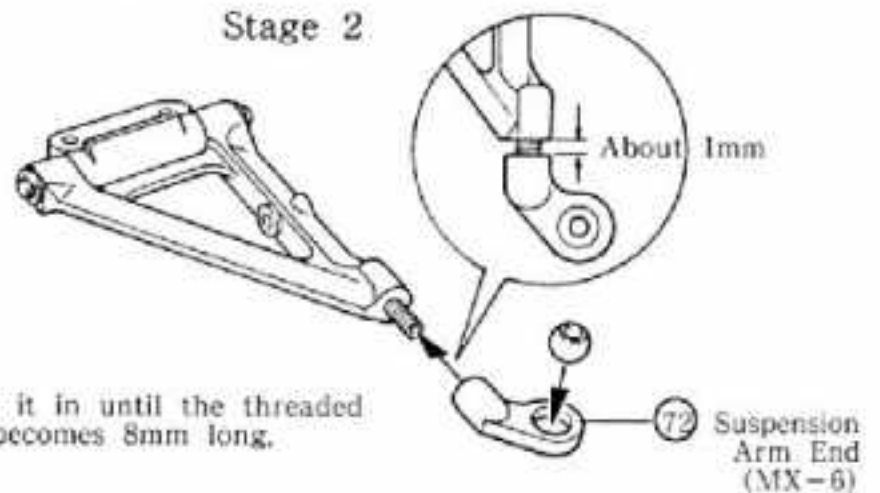

### Stage 3

Fix the part 70 inversely.

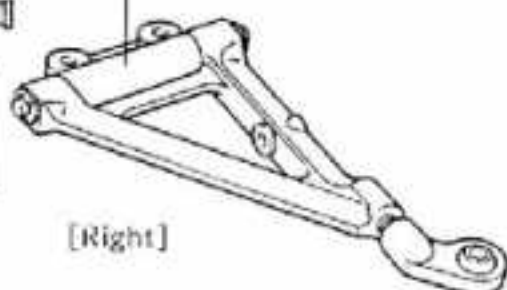

### Stage 4

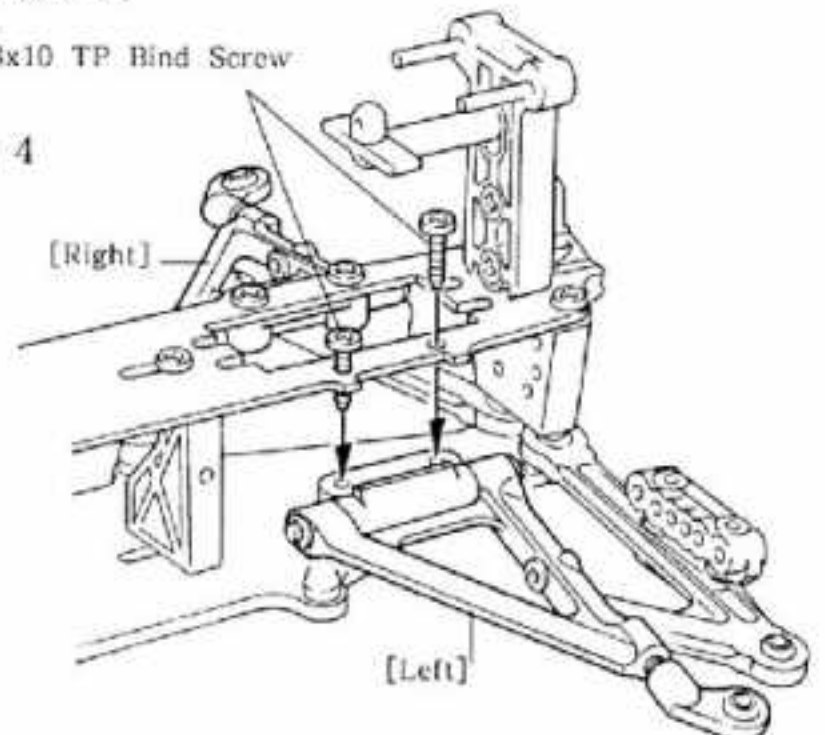

## 8 ASSEMBLY OF REAR HUB

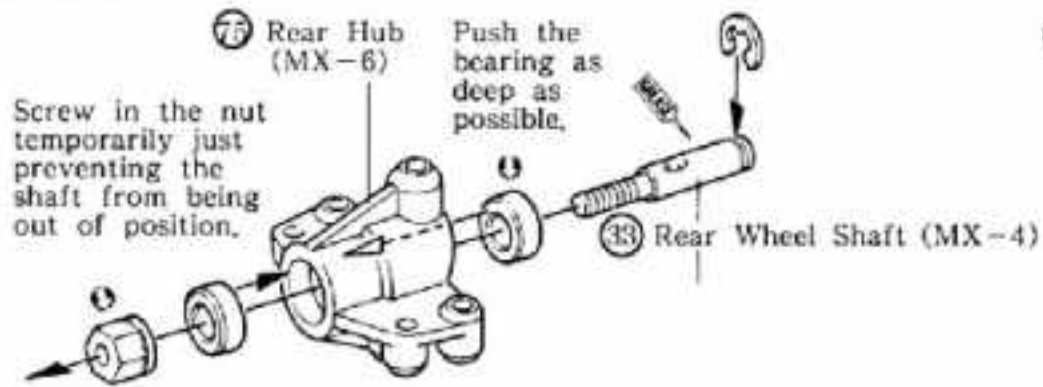
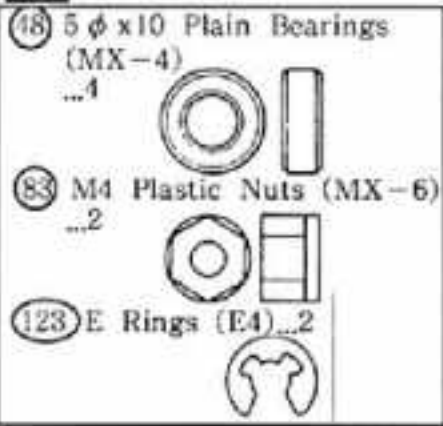

\* Assemble two of this portion.

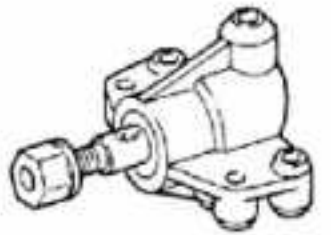

## 9 INSTALLATION OF REAR HUB

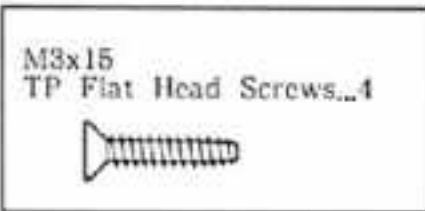

[Installation Position and Orientation]

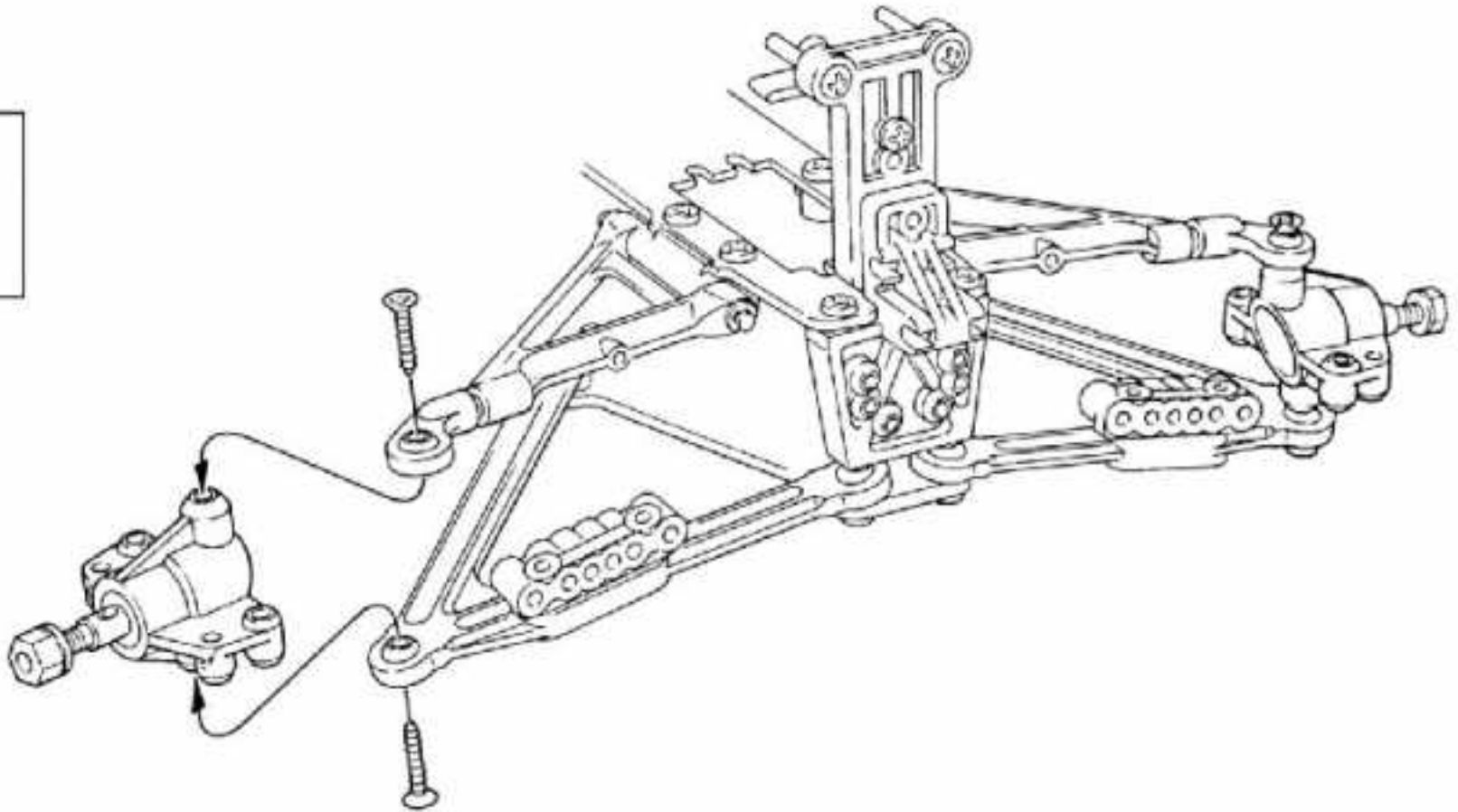
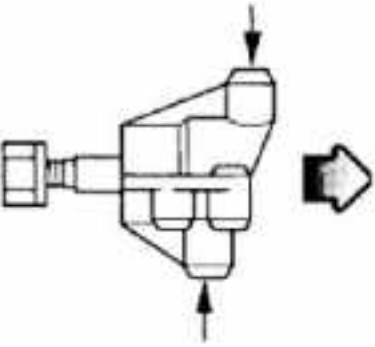

## 10 INSTALLATION OF REAR SHOCK AND REAR TIE ROD

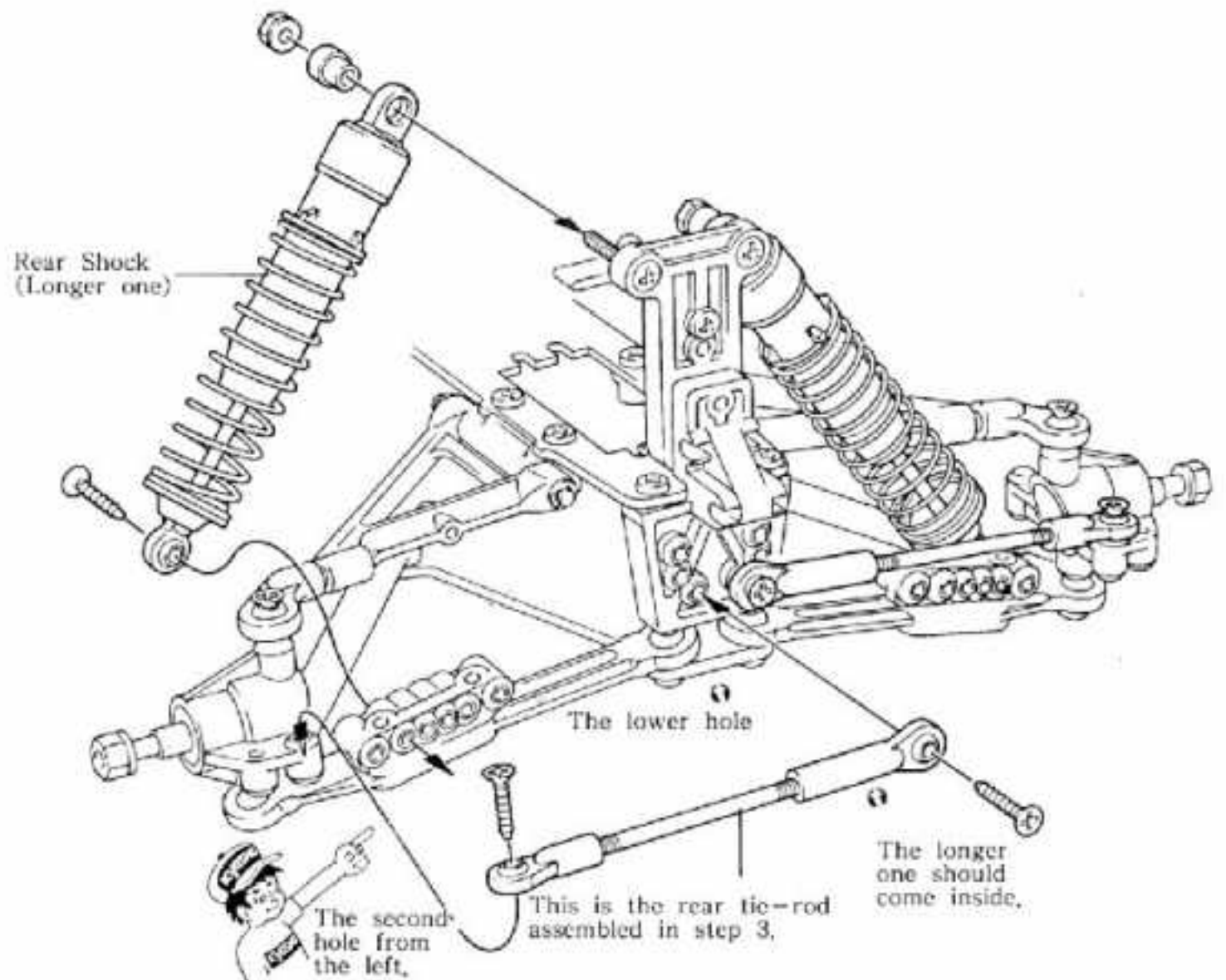
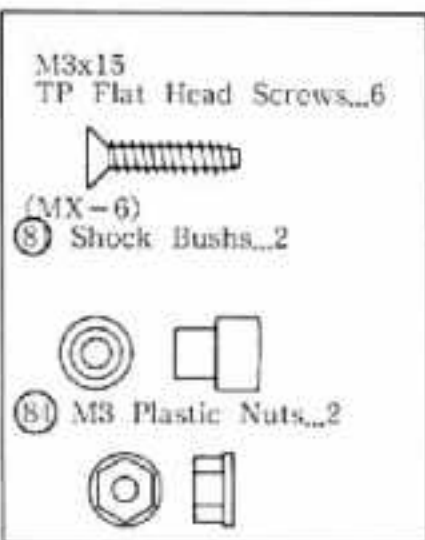

# 11 ASSEMBLY OF DIFFERENTIAL GEAR

## Stage 1

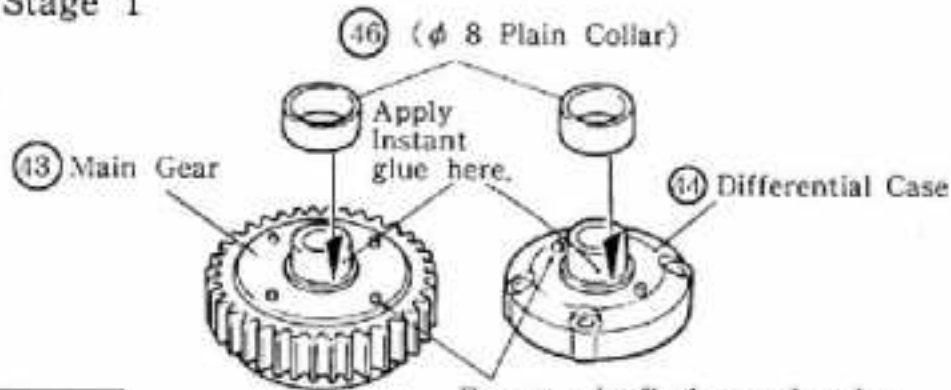

M2x10  
TP Roud Head Screws...4

(40) Bevel Shaft...1

(46) 8 φ Plane Bearing Collars...2



Remove six flushes and make the surface flat and smooth.

IN THE CASE OF EMPLOYING THE OPTIONAL BALL BEARINGS AS SHOWN IN STEP 12, DO NOT FIT THE PLAIN BEARING.

## Stage 2

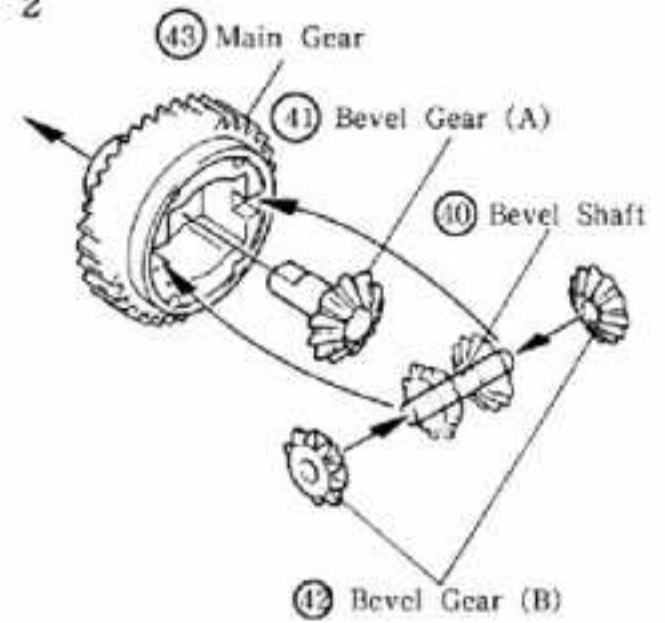

## Stage 3

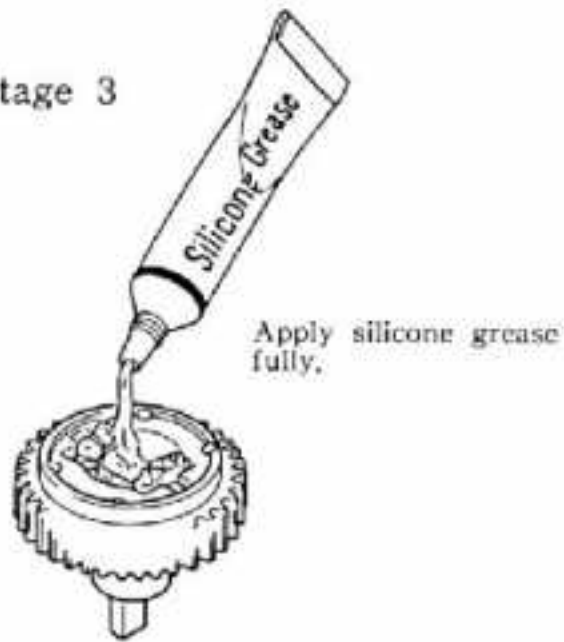

## Stage 4

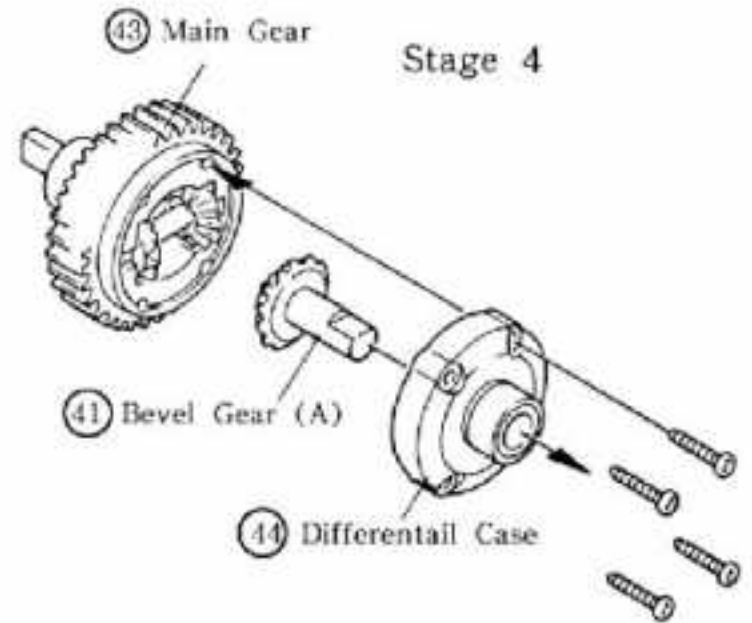

# 12 INSTALLATION OF JOINT

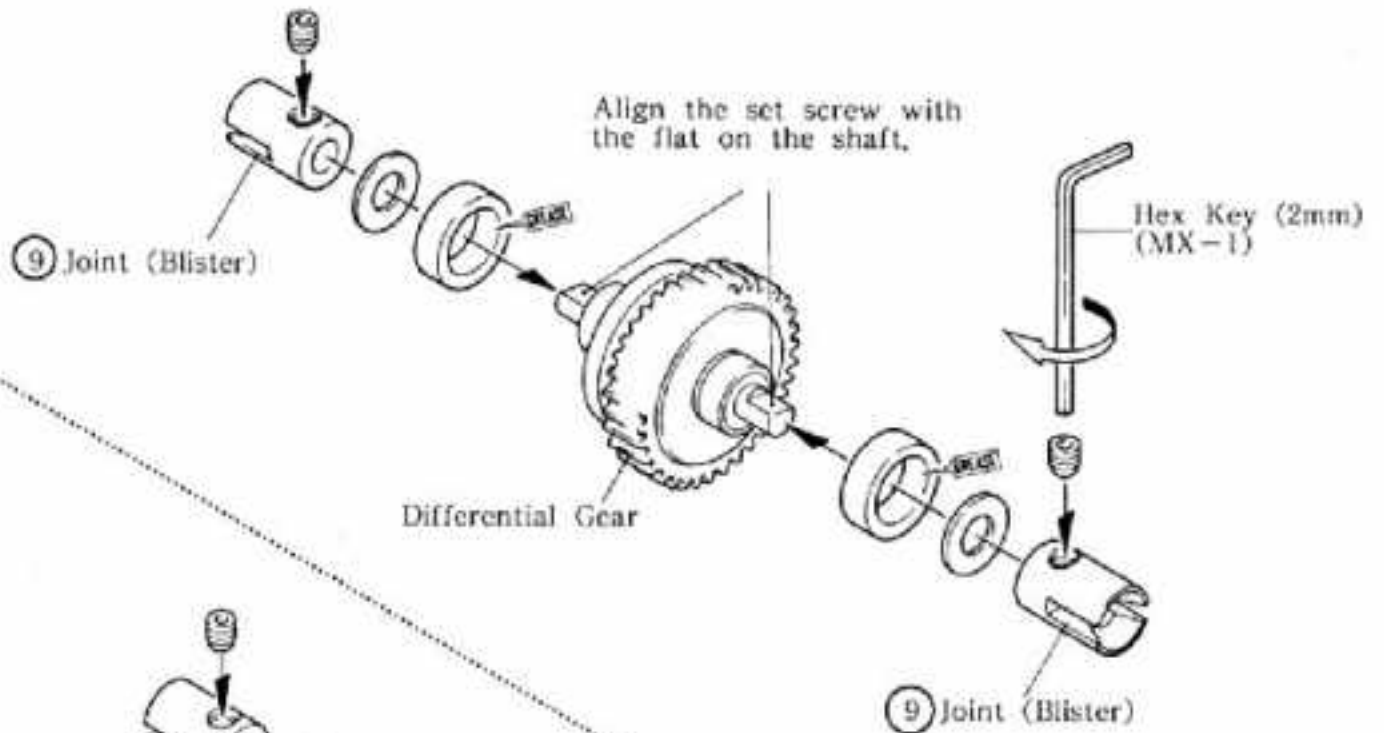

M4x4 Set Screws...2

M5 Washers...2

(19) 10 φ x14 Plane Bearings (MX-4)

### OPTION

When making use of the optional ball bearings...

#1911 8 φ x14 Ball Bearing

### 13 CUTTING OF GEAR COVER

M3x6 Bind Screw...1



#### Stage 1

16 Motor Plate (Blister)

38 Center Gear Shaft (MX-4)

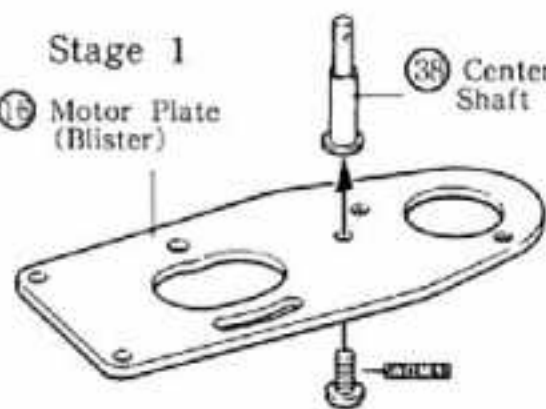

#### Stage 2

Make a hole of 3mm diameter at the marked point.

66 Gear Cover (MX-5)

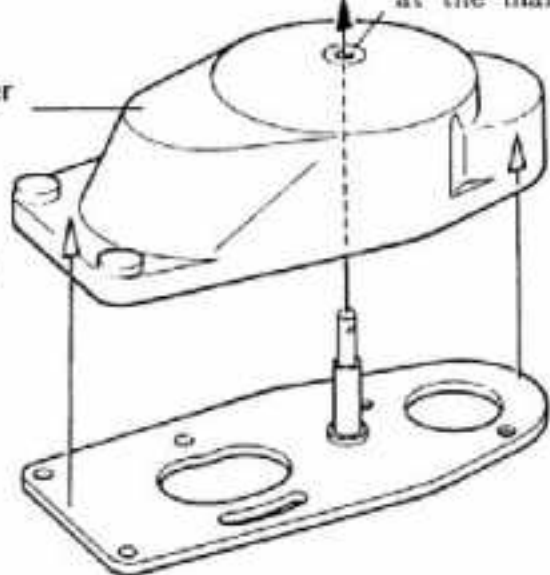

#### Stage 3

Cut off the diagonally lined edge. The gear cover will be fitted in step 24.

The round cutting scissors, offered by Kyosho Co., is a very handy tool for this job here.

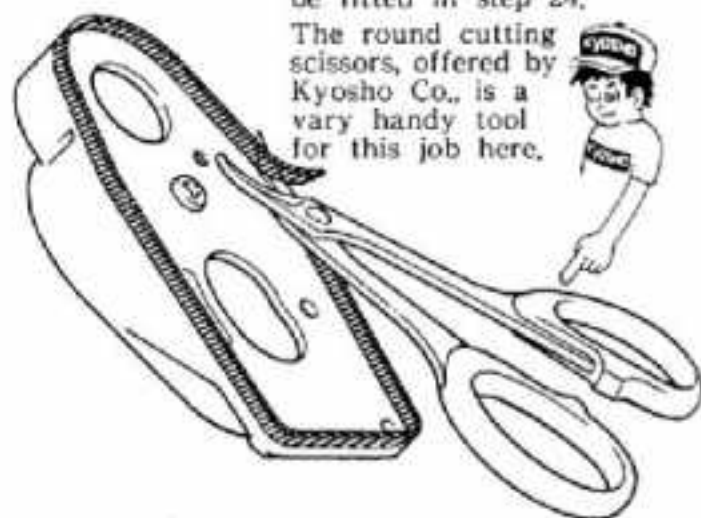

### 14 INSTASLLATION OF COUNTER GEAR AND FINAL PINION

M4x4 Set Screw...1



[M4x4] 37 2 φ x11 Pin...1

48 5 φ x10 Plane Bearing...1



#### Stage 1

5 Counter Gear (Blister)

39 Counter Gear Shaft (MX-4)

Remove the flush.

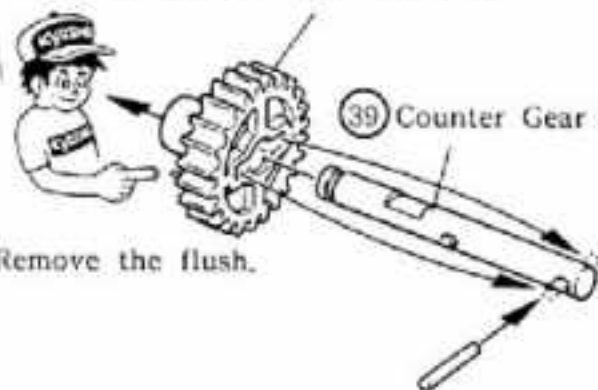

#### Stage 2

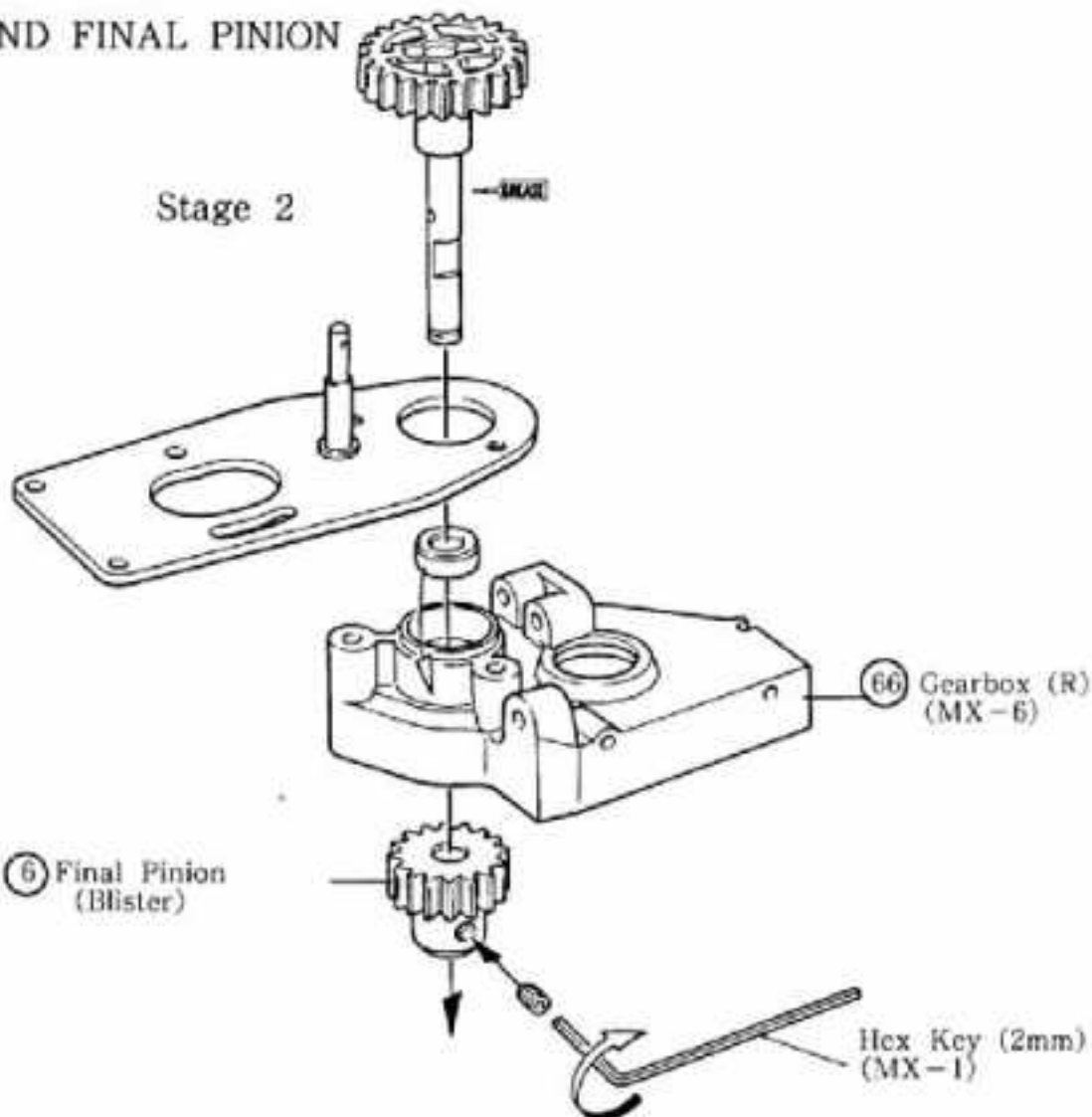

Hex Key (2mm) (MX-1)

### 15 ASSEMBLY OF GEAREBOX

M3x18 TP Round head Screws...2

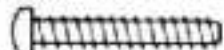

M3x35 Bind Screws...2



48 5 φ x10 Plane Bearing...1 (MX-4)

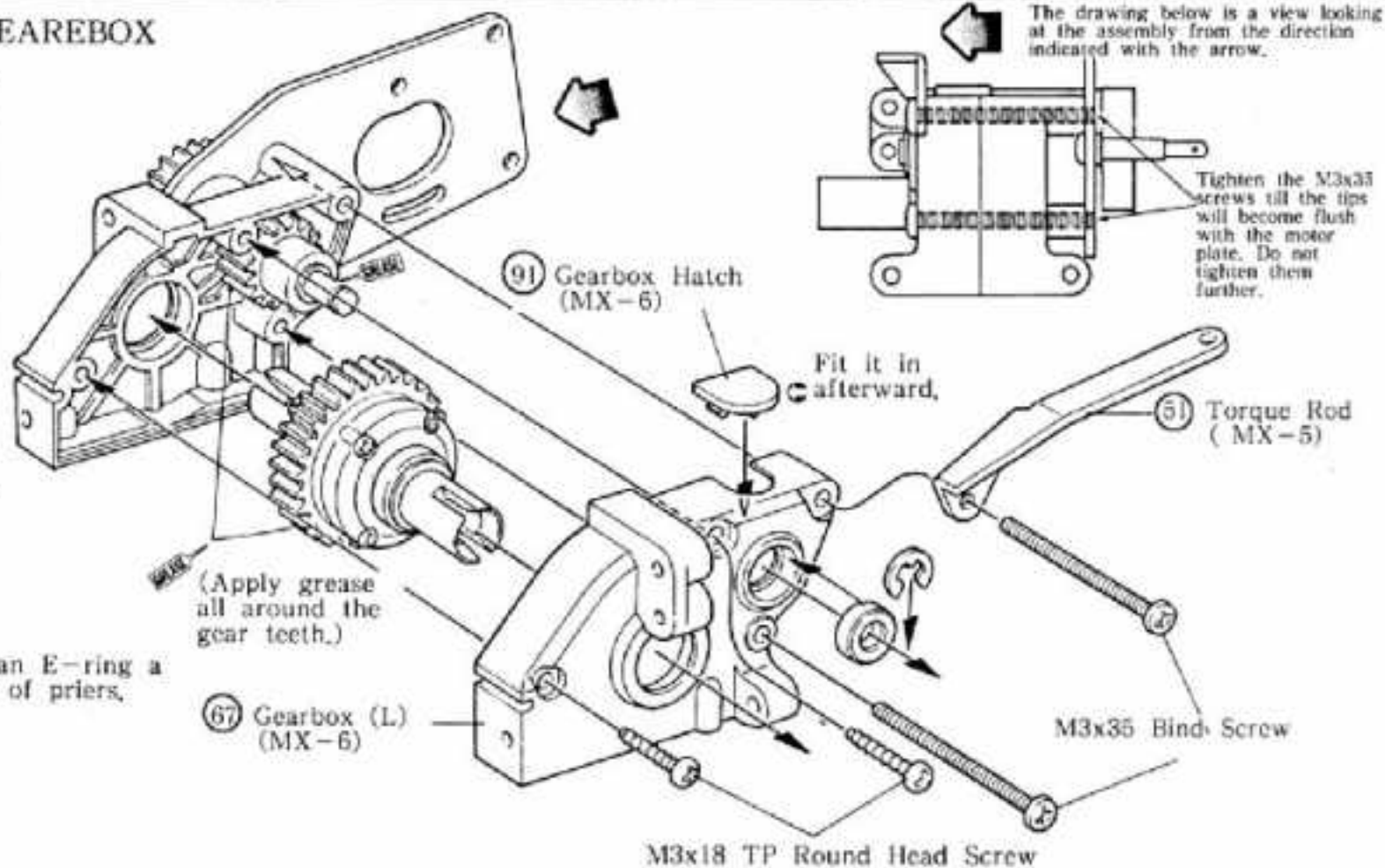

The drawing below is a view looking at the assembly from the direction indicated with the arrow.

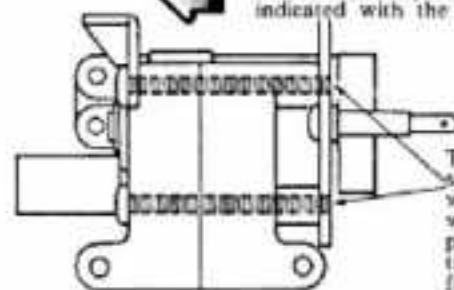

Tighten the M3x35 screws till the tips will become flush with the motor plate. Do not tighten them further.

Fit it in afterward.

51 Torque Rod (MX-5)

(Apply grease all around the gear teeth.)

Fit an E-ring a pair of priers.

67 Gearbox (L) (MX-6)

M3x35 Bind Screw

M3x18 TP Round Head Screw

## 16 INSTALLATION OF FRONT SHOCK STAY

- M3x10 TP Bind Screws...6
- M3x18 Bind Screws...2
- M3 Nuts...2
- M2.6 Pillow Balls (Black) (MX-7)...2

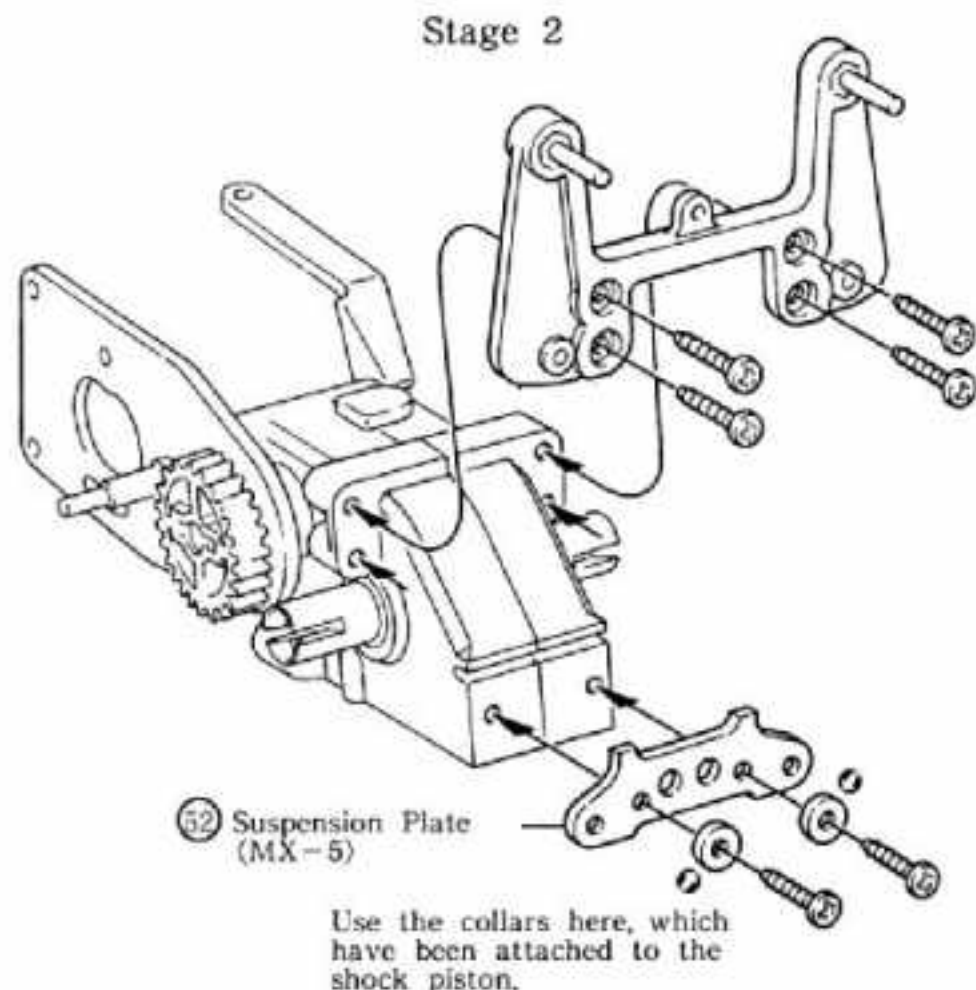
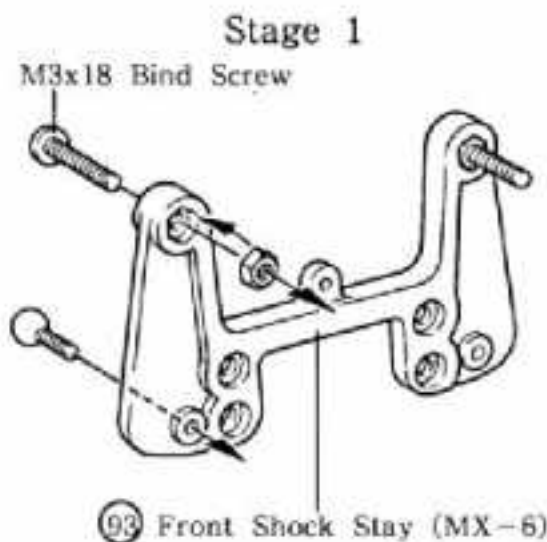

## 17 INSTALLATION OF KNUCKLE ARM

- M2.6 Nuts...2
- M4 Nylon Nuts...2
- 113 M2.6 Pillow Balls (Black) ...2 (MX-7) [MX-4]
- 114 King Pins...4
- 115 5 φ x10 Plain Bearings ...4

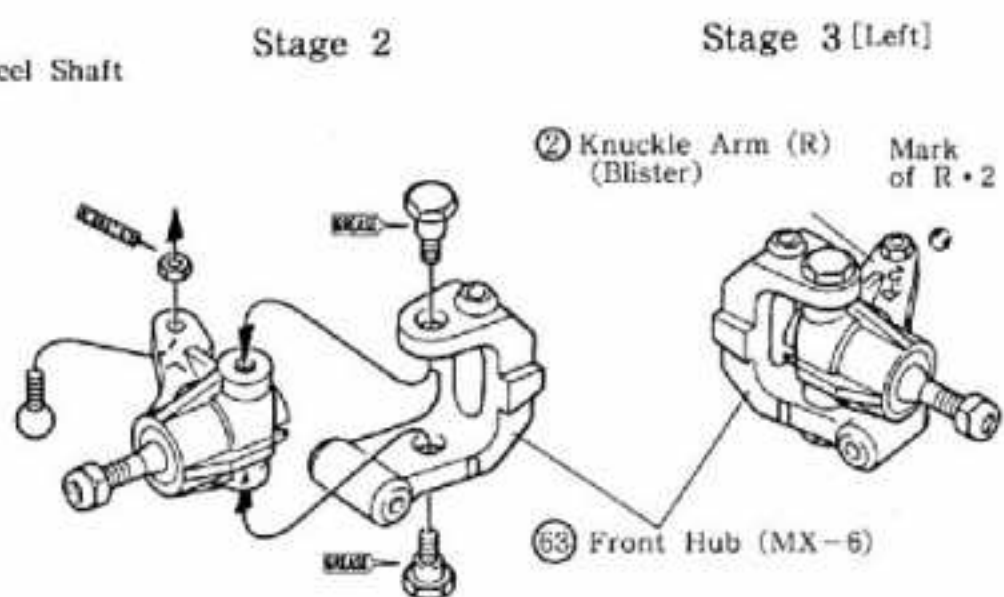
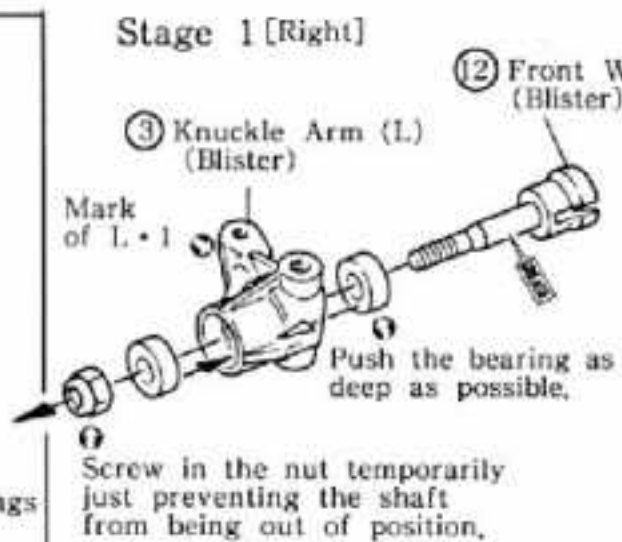

## 18 INSTALLATION OF FRONT SUSPENSION ARM

- M4x8 Set Screws...2
- 23 E Rings (E2.5)...6
- [MX-7]
- 105 Suspension Shafts (Short)...2
- 107 Suspension Shafts (Long)...2
- When adopting the optional stabilizer...
  - 61 Stabilizer Ends...2 (MX-6)
- 122 E Rings (E3) (Black) ...2

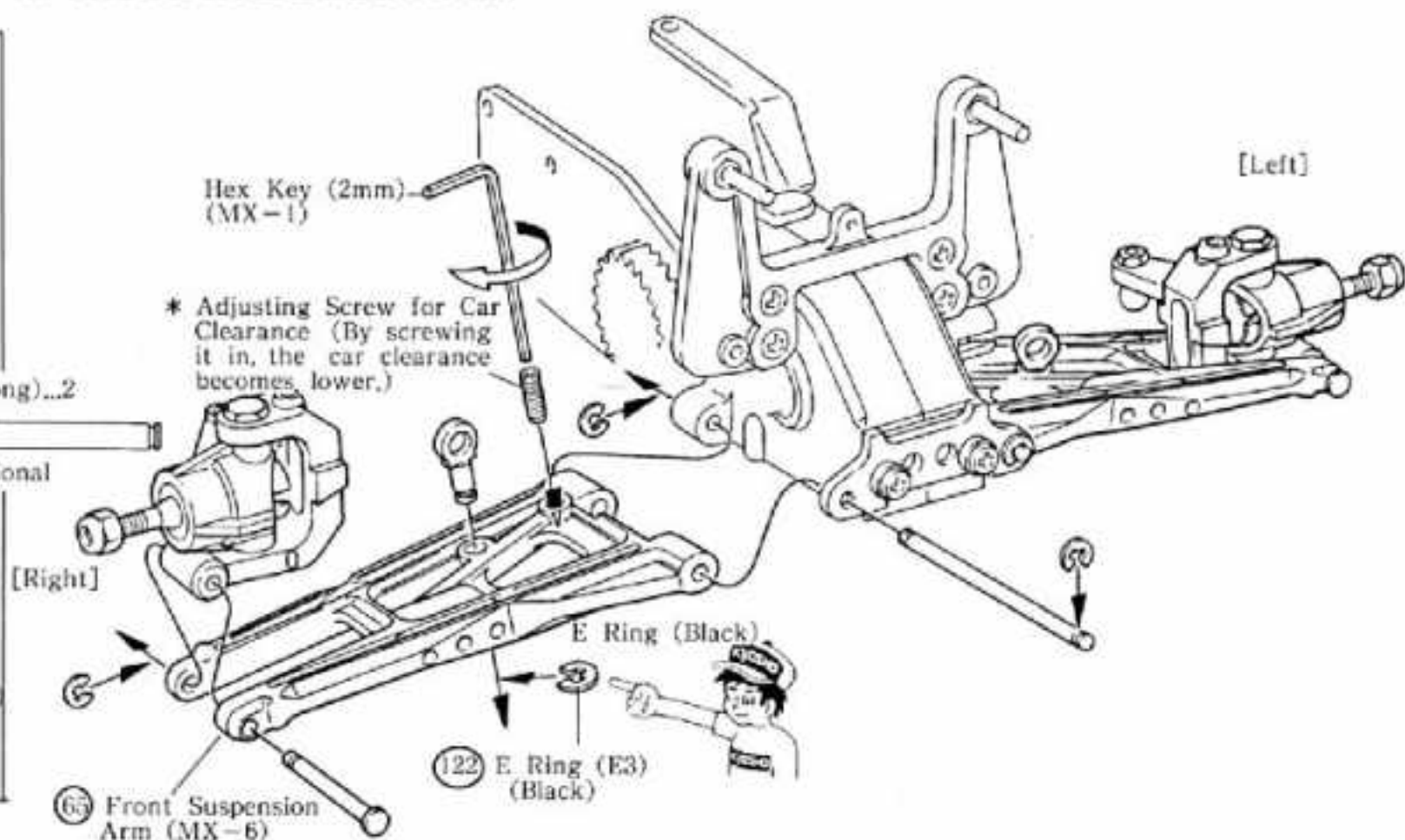

# 19 INSTALLATION OF GEARBOX AND BUMPER

- M3x10 Round Head Screws...2
- M3x10 TP Bind Screws...5
- M3x15 TP Flat Head Screws...2
- M3 Flange Nuts...2

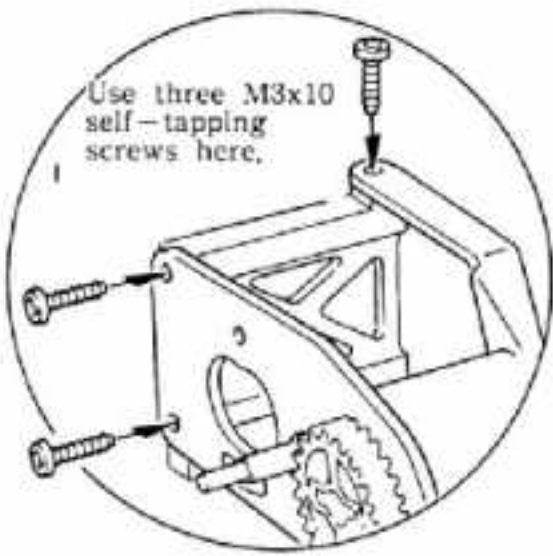
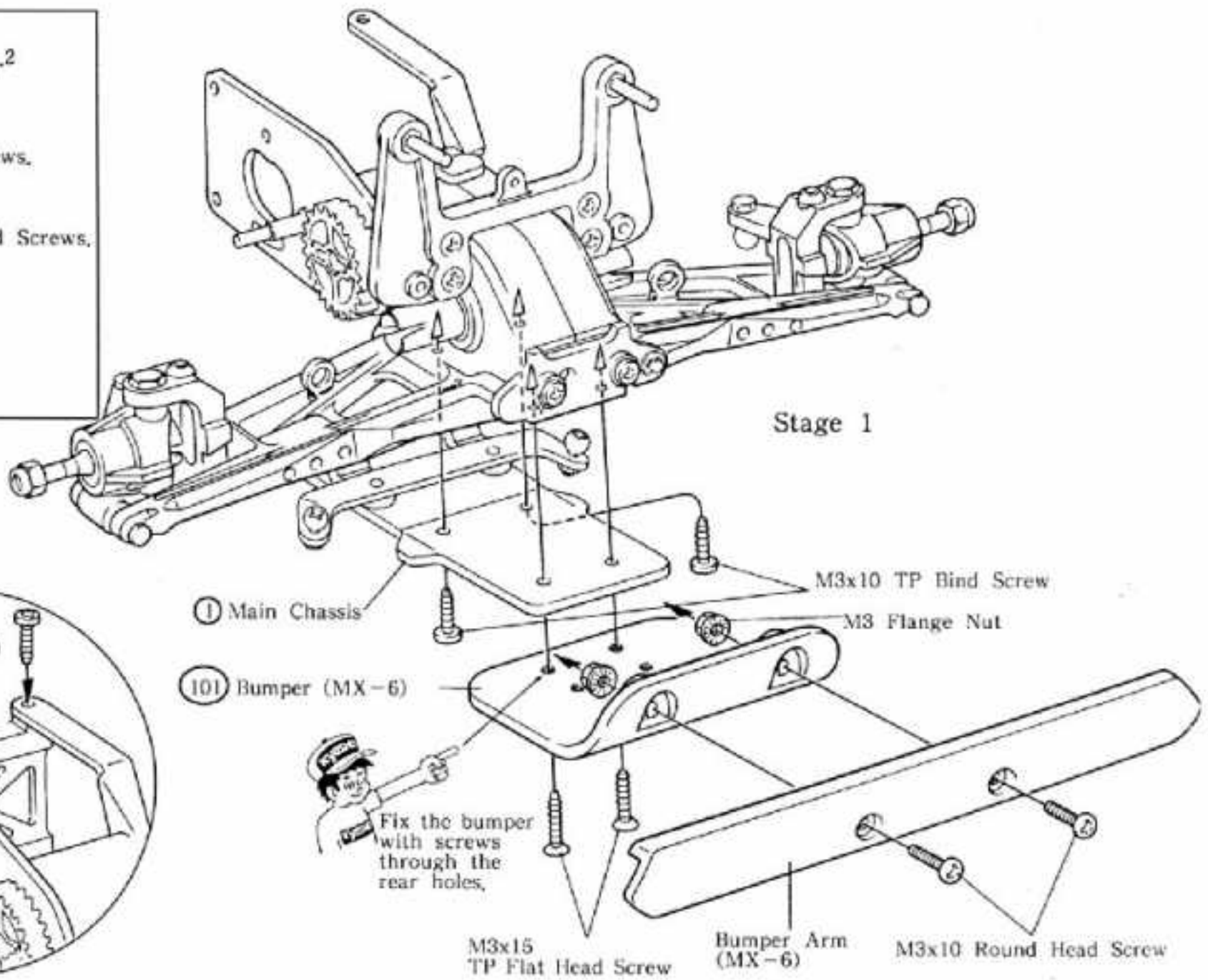

# 20 INSTALLATION OF ROD PARTS (FRONT PORTION)

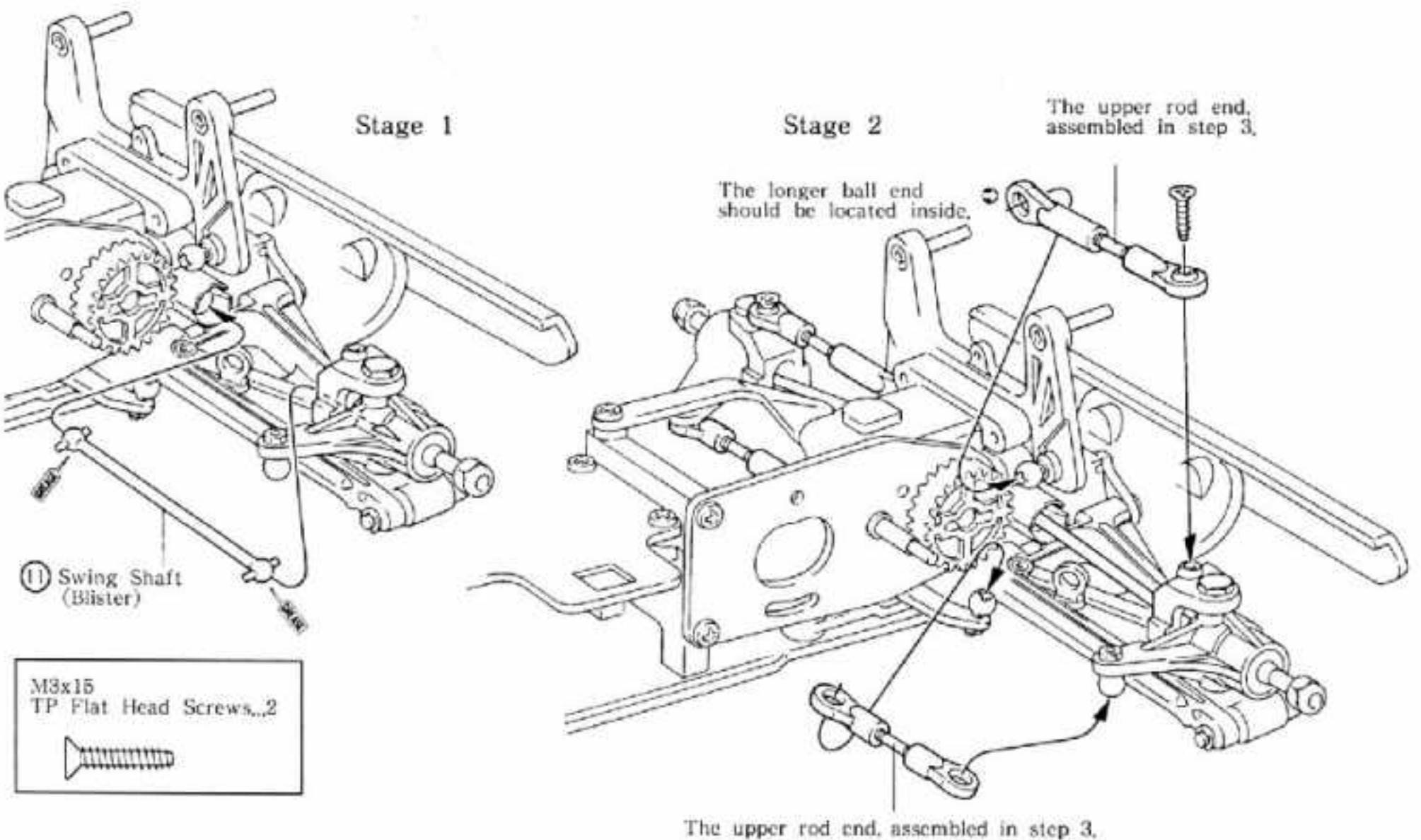

- M3x15 TP Flat Head Screws...2

## 21 INSTALLATION OF FRONT SHOCK

M3x15  
TP Flat Head Screws...2



[MX-6]

⑧ Shock Bushes...2



⑨ M3 Plastic Nuts...2

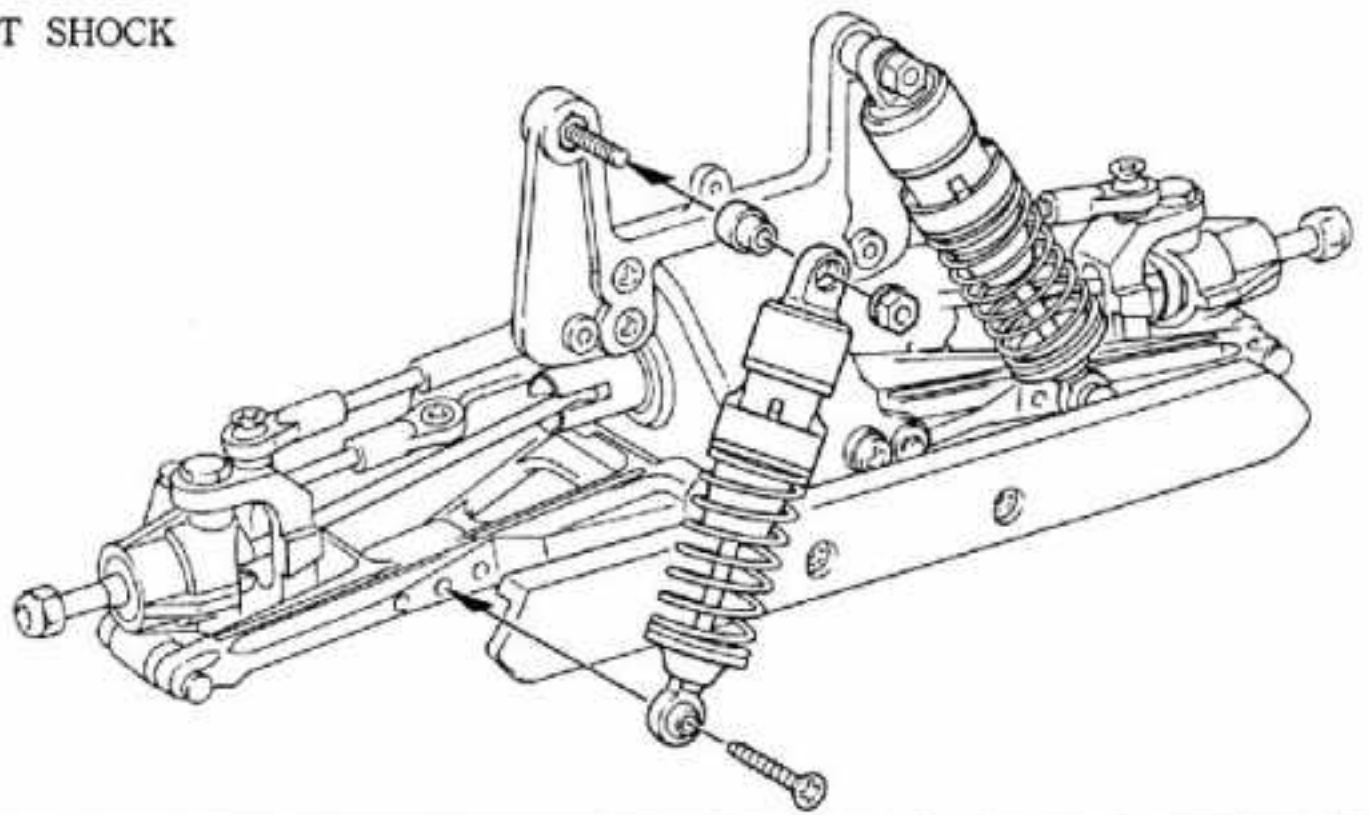

## 22 INSTALLATION OF CENTER GEAR

M4 Washers...2



[MX-4]

⑮ O Ring (P3)...1



⑰ 4 φ x8 Plain Bushins...1

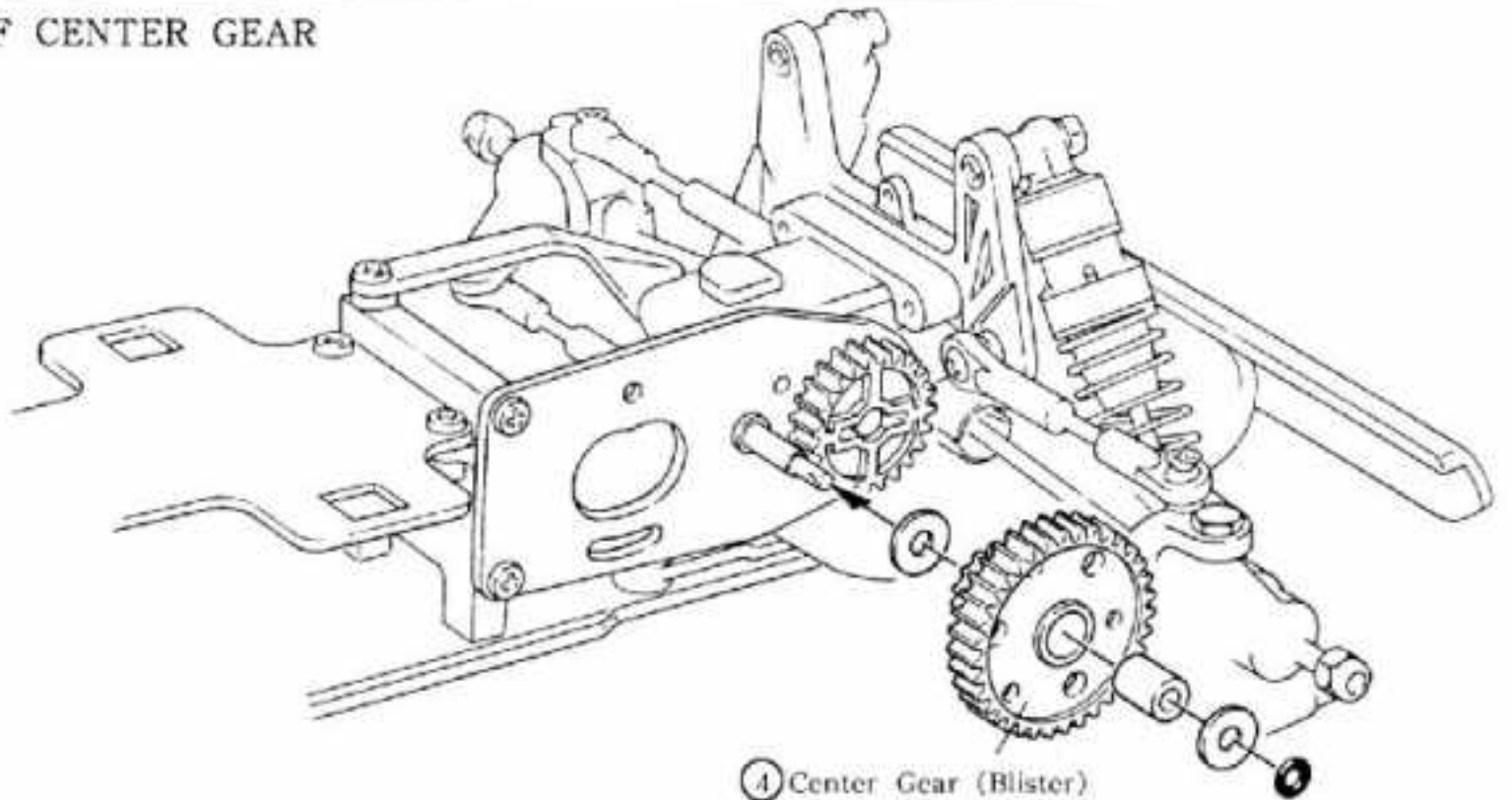

④ Center Gear (Blister)

## 23 INSTALLATION OF MOTOR

Connect the red lead to the plus terminal, and the white lead to the minus one.

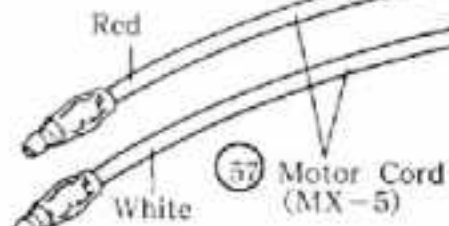

M3x6 Bind Screws...2



M3x3 Set Screw...1



[Pinion Gear Set]

about 15mm

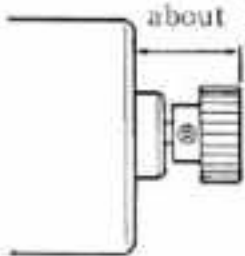

[Adjustment of Backlash]  
(Gear Meshing)



Adjust the backlash of the gear by loosening the two screws indicated with arrows, and moving the lower screw in the direction of the arrow.

⑩ Le Mans 240ST Motor (Blister)

Align the set screw with the flat on the shaft.

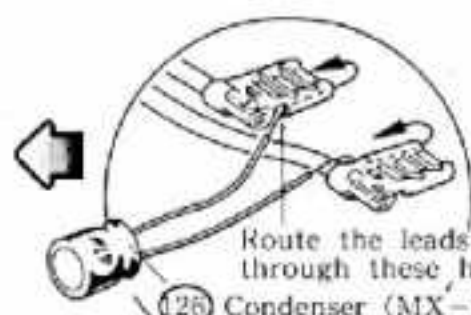

Route the leads of the condenser through these holes here.

⑫ Condenser (MX-5)

M3x6 Bind Screw

M3x3 Set Screw

Hex Key (1.5mm)

⑦ Pinion Gear (15T) (Blister)

## 24 INSTALLATION OF GEAR COVER

124 Hook Pins...1  
(MX-1)

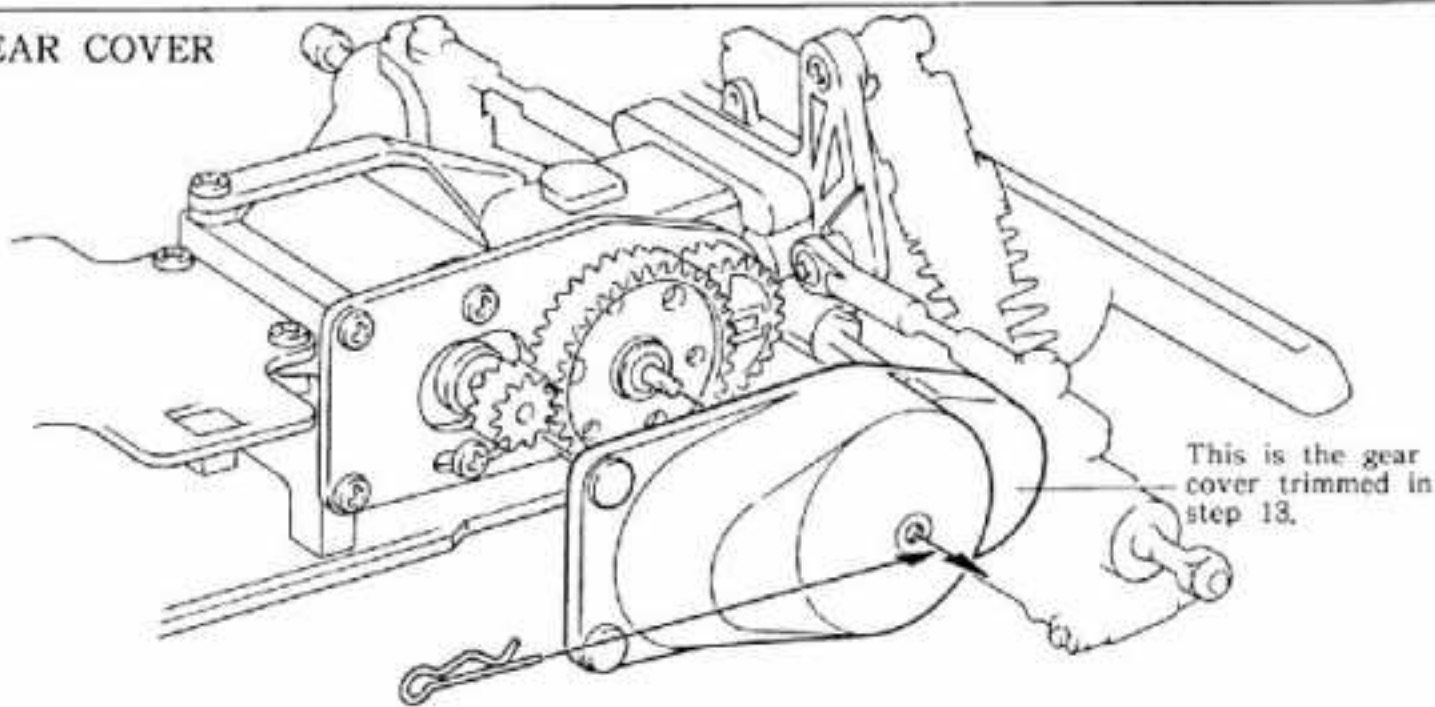

## 25 FIXING OF TIRE

37 2 φ x11 Pins...2  
(MX-4)

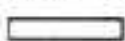

Stage 1

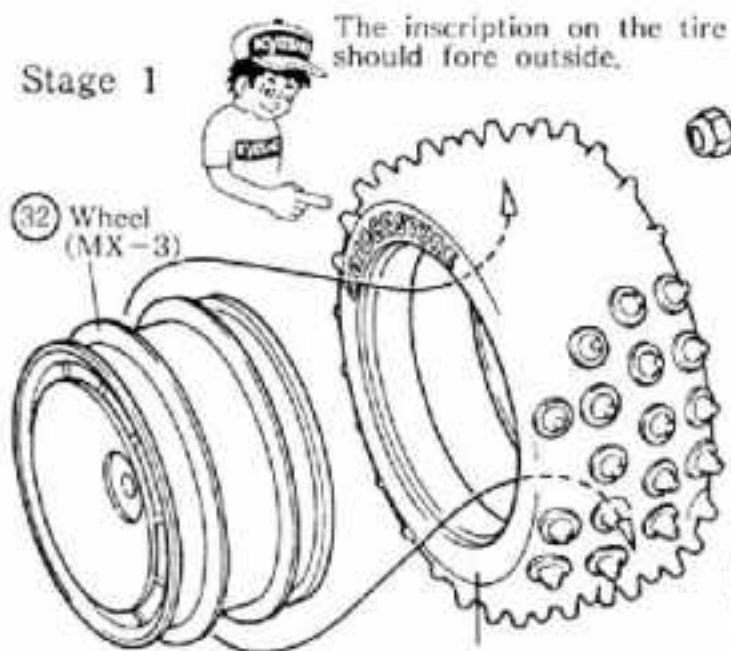

Align the hexagonal point.

Small

The side with the bigger hole should face inside.

[Front]

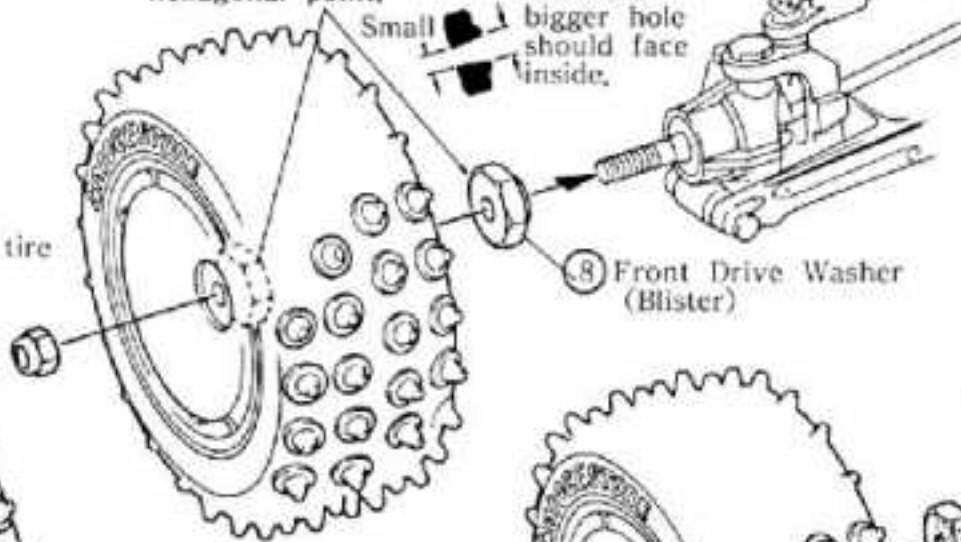

Stage 3

[Rear]

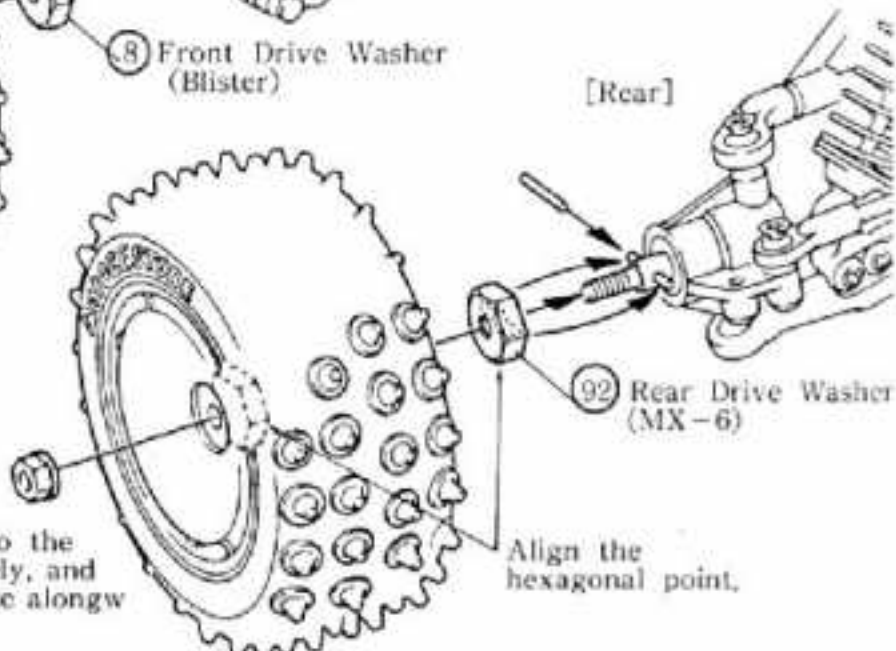

Stage 2

Fit the tire into the wheel completely, and pour instant glue along with the seam.

## ● INSTALLATION OF RADIO AND LINKAGE 26 - 34

### 26 HOW TO CHECK RADIO SYSTEM

Operate the radio control units in order of the numerical figures.

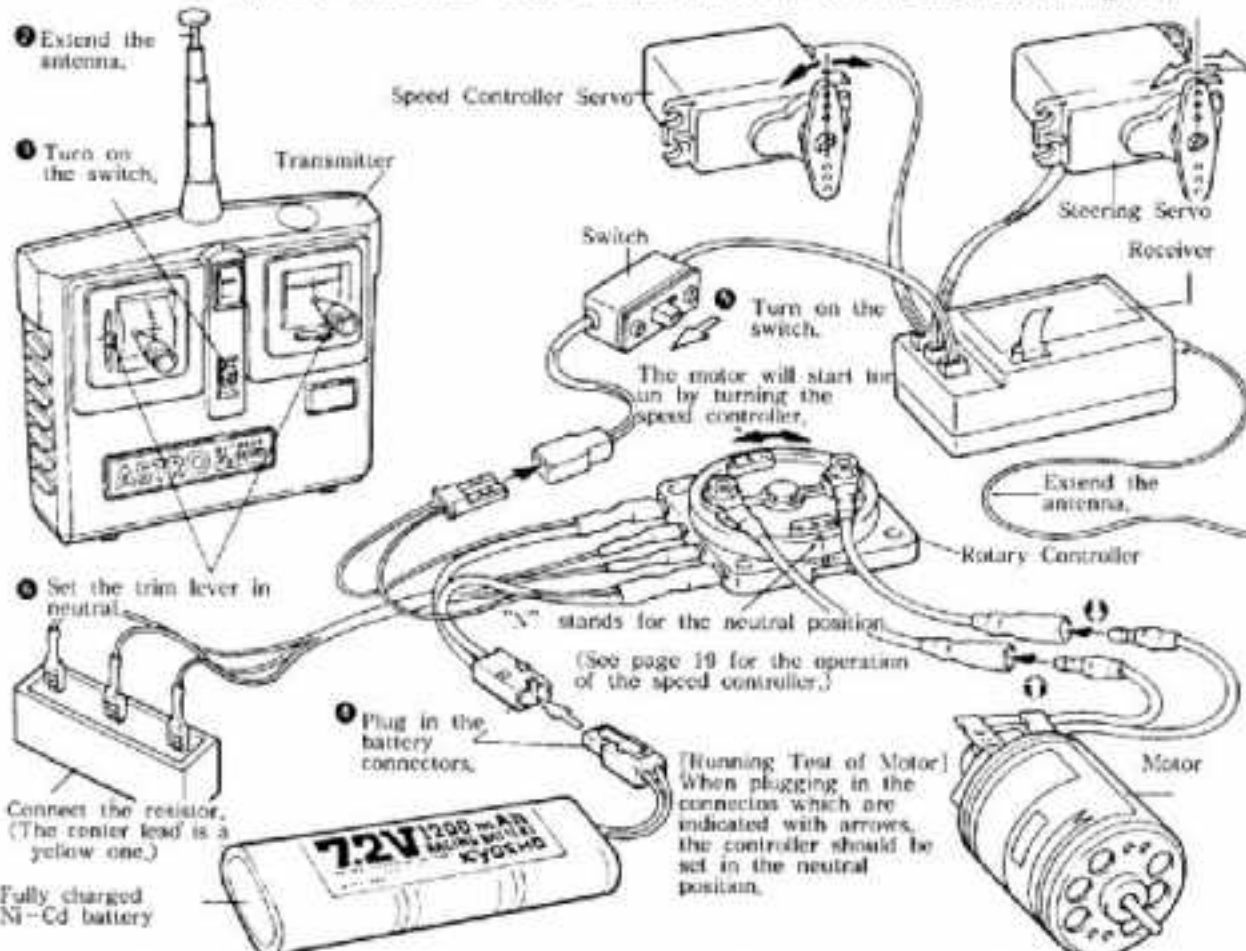

**BEC**  
BATTERY ELIMINATOR CIRCUIT

This model is for BEC syst enradio only.

A two channel radio is composed of things like a transmitter, receiver, servos, and battery.

- Transmitter -- It is effect a control box. Signal waves are transmitted through an antenna according to the stick movements.
- Receiver ---- Receives the signals from the transmitter and send them to the servos.
- Servo ----- They really move the control mechanism of a model car in accordance with the signals from the receiver.
- Antenna ---- An antenna on the transmitter sends signals, and one on the receiver accepts them. They should be fully extended.
- Trim Lever -- They will adjust the neutral position of servos, thus regulate the steering and advancing controls finely.
- Battery ----- You can tell the amount of electricity in a battery and how the signals are emitted.
- Servo Horn --- They are intermediate devices on the servos to activate the controls. There are several types in shape. They should be selected depending upon the usage.

When switch on the radio...  
Get the switches in order from transmitter to receiver.

When switch off the radio...  
In order from receiver to transmitter.



## 27 INSTALLATION OF SERVO

[MX-6]  
M3x10  
TP Bind Screws...8

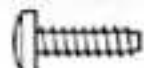

- With a mini servo, use four screws: eight screws in all.

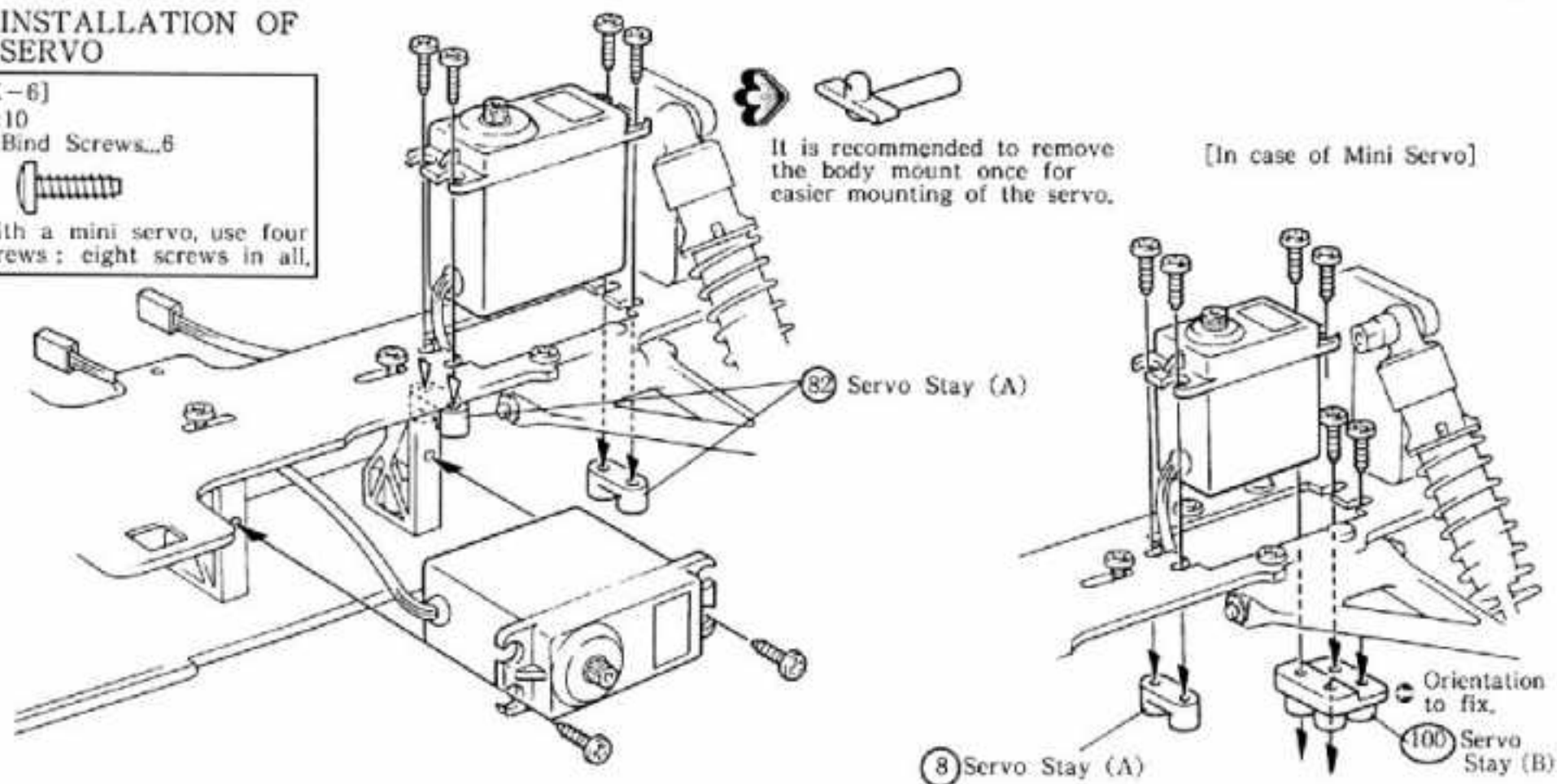

## 28 ASSEMBLY OF SERVO SAVER

Stage 1



Press it in.

Stage 2



- Futaba, KO



- Sanwa (Big Size)

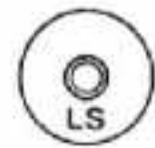

- Sanwa (Mini Size)

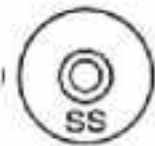

Stage 3

Servo Horn (There are several types of saver horns depending upon the servo to employ.)



## 29 STEERING LINKAGE

Stage 1 Bend it referring to the life size drawing below.

5 Steering Rod (MX-5) [Actual Size]

79 Saver Washer...1 (MX-6)

- Futaba, KO  
M2,6x12  
TP Bind Screw...1

- Sanwa  
M3x10  
TP Bind Screw...1

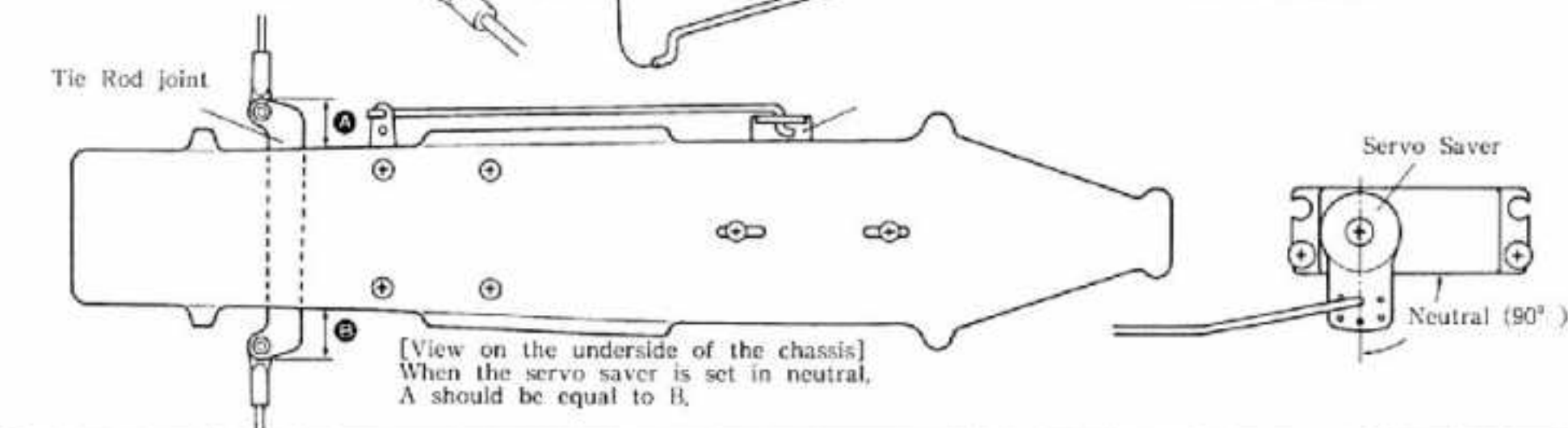

Stage 2.

- After having installed the parts:
- (1) Adjust the location of the servo to find the position where it will make  $A=B$  as shown below.
  - (2) After the adjustment, tighten the four screws firmly to fix the mount.

### 30 INSTALLATION OF RESISTOR AND SWITCH

M2x4 Round Head Screw...1



M3x10 TP Bind Screws...4

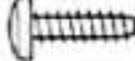

M2x4 Round Head Screw

62 Resistor Bracket (MX-5)

14 Resistor (Blister)

15 Resistor Cover (Blister)

97 Resistor Mount (MX-6)

The screws provided with your radio control set.

Switch Plate

96 Switch Holder (MX-6)

Switch

### 31 INSTALLATION OF SPEED CONTROLLER

M3x10 Round Head Screws...2



M3 Nuts...2



Use the collar here which has been attached on the shock piston,

13 Rotary Speed Controller (Blister)

[Connection of Resistor Leads]

The center one is yellow in color.

[Connection of Motor Cord] Plug in the connectors, red one to red one, and white one to black one,

### 32 INSTALLATION OF RECEIVER

61 Antenna Pipe (MX-5)

Plug in the connectors of the switch and servos.

BEC connector from the switch

[Putting the cords in order]

Bundle it tightly and cut off the excess,

58 Double Sided Tape (MX-5)

59 Strap (S) (MX-5)

Pass the antenna wire through.

Route the lead wire under the motor cord.

### 33 SPEED CONTROLLER LINKAGE

- M2x12 TP Round Head Screw...1
- M2.6x6 TP Bind Screw...1
- M2.6x12 TP Bind Screw...1
- M2.6 Washer (Black)...1
- (MX-7) Linkage Collars...2
- (10) 4.8 φ Ball End...1
- (12) 4.8 φ Ball End...1
- (17) 4.8 φ Ball...1

**Stage 1**  
Cut off the shaded on the servo horn.

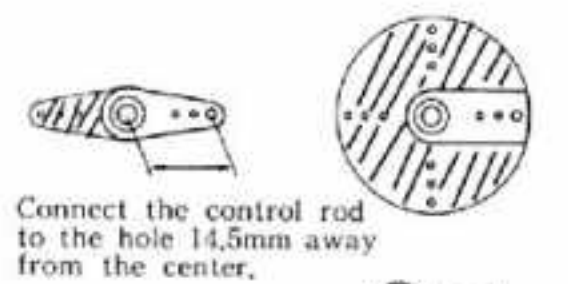

Connect the control rod to the hole 14.5mm away from the center.

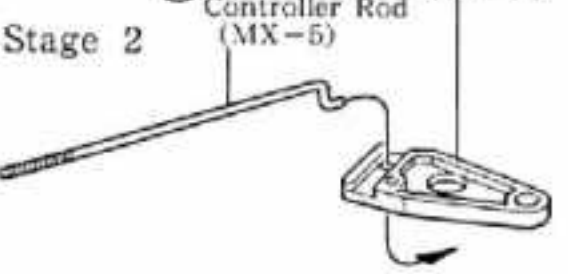

**Stage 3** M2.6x6 TP Bind Screw

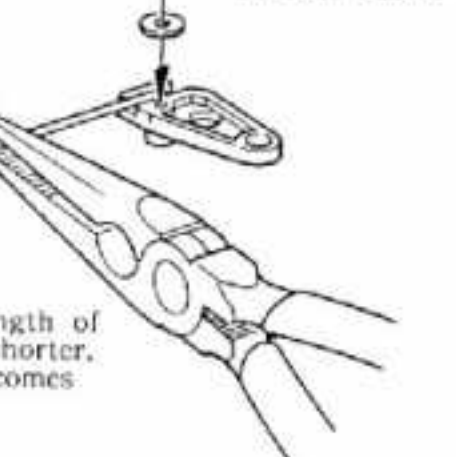

By screwing it in, the length of the control rod become shorter, by screwing it out it becomes longer.

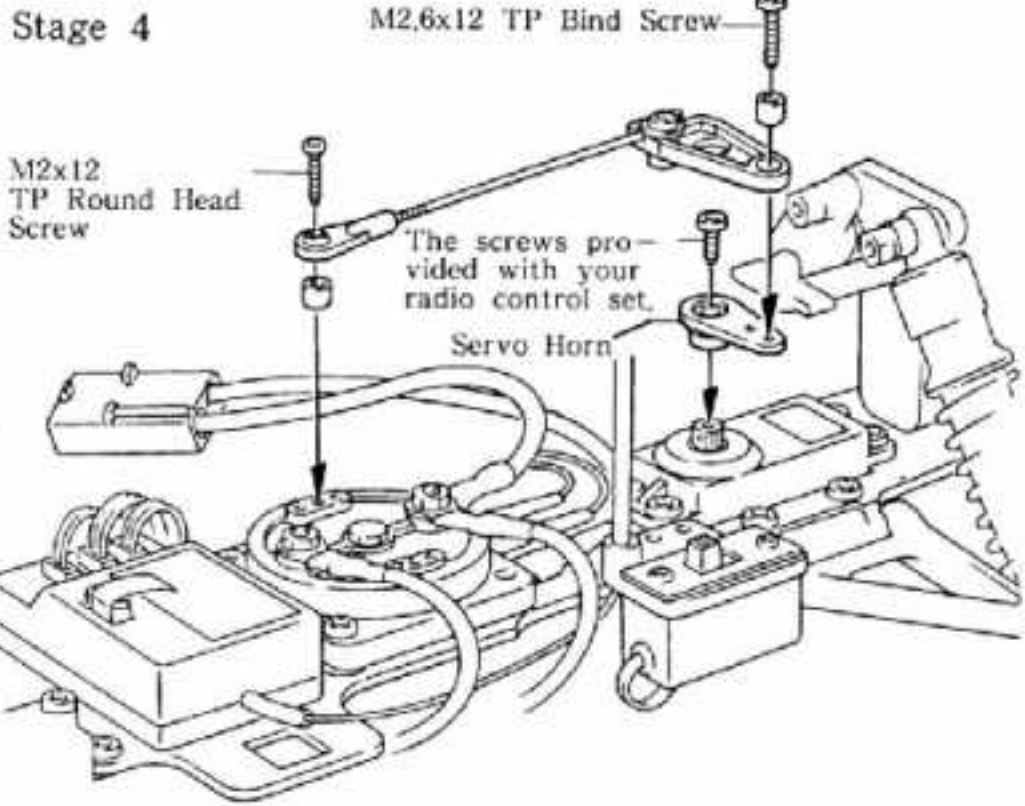

When it is A, the state of B should be attained. (Confirm C, If not, adjust it with D or E.)

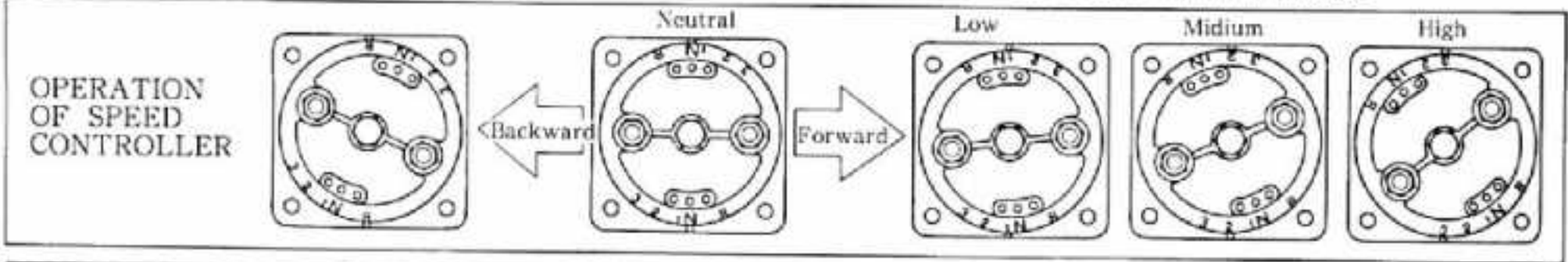
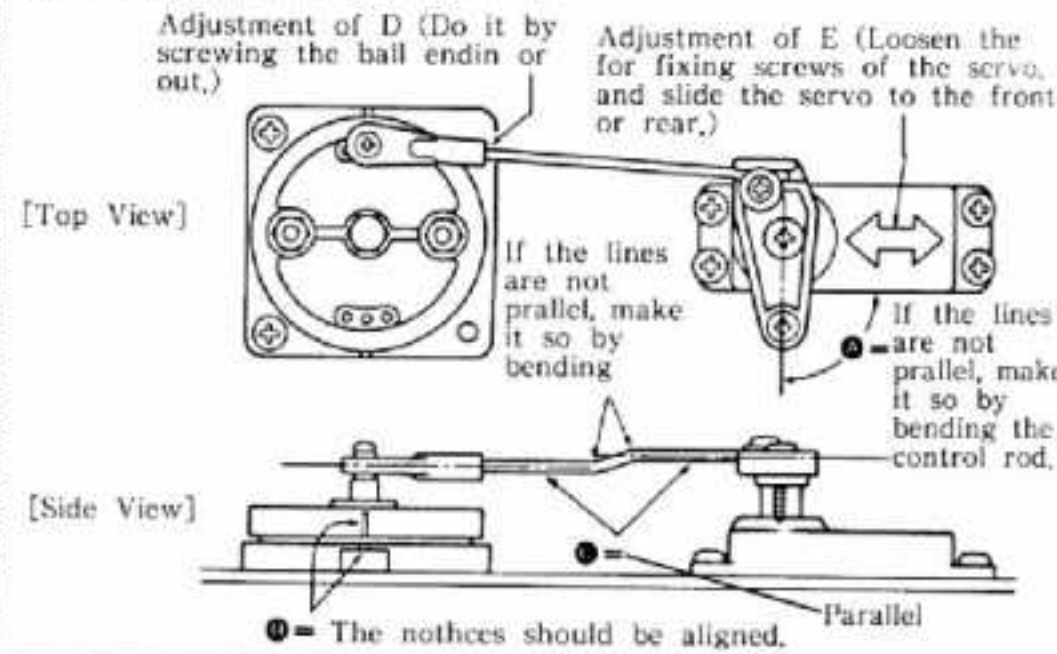

### 34 MOUNTING OF NI-CD BATTERY

Remove the Ni-Cd battery pack from the car when it is not in operation or being stored.



(18) Battery Holder (MX-7)

Cellophane tape or residue of the decals,

(20) Ni-Cd Strap (MX-5)

**Stage 2**

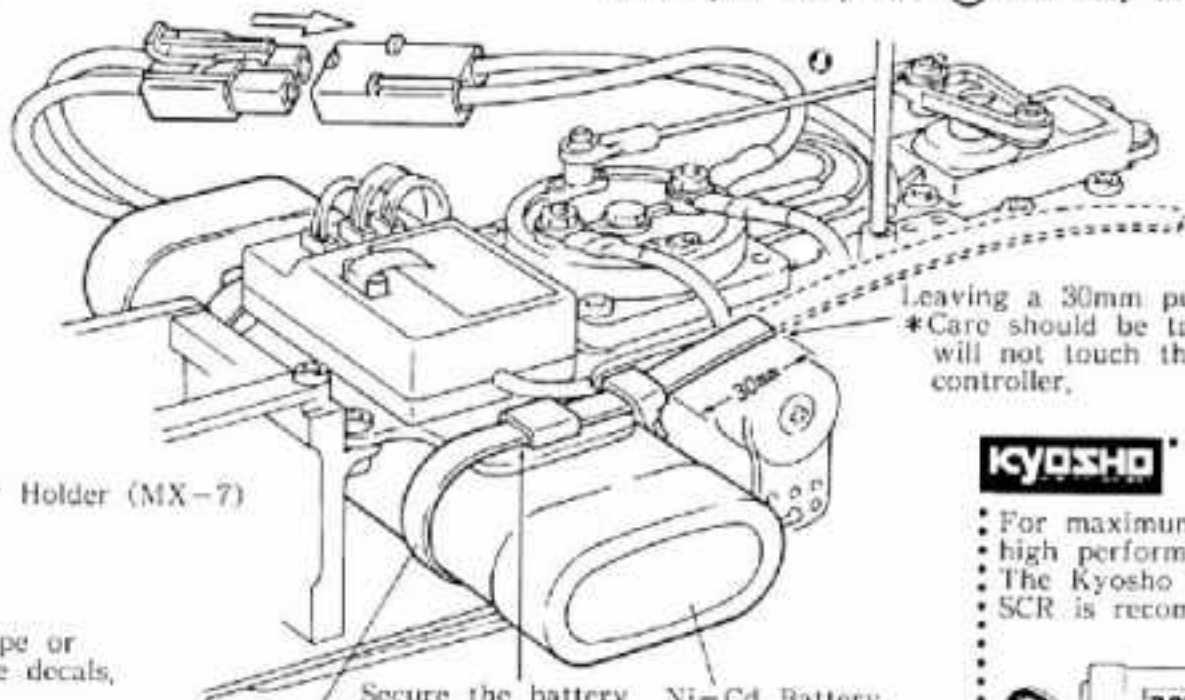

Secure the battery to the holder (18) by bundling them together.

Ni-Cd Battery Use the battery pack which has been fully charged.

\*Be careful that the lead wires and the control rods will not rub against the speed controller arm. (Bundle them together with nylon strap (S) (20) and keep them in a safe position.)

Leaving a 30mm pull, cut off the excess. \*Care should be taken that the strap will not touch the servo saver or the controller.

**KYOSHO**

- For maximum performance, use a high performance battery.
- The Kyosho 7.2V Sprint Battery SCR is recommended.

No.2310

● CUTTING AND MOUNTING OF BODY

**35** CUTTING OF BODY

- Cut off shaded area.
- Finish the cut line with sander.

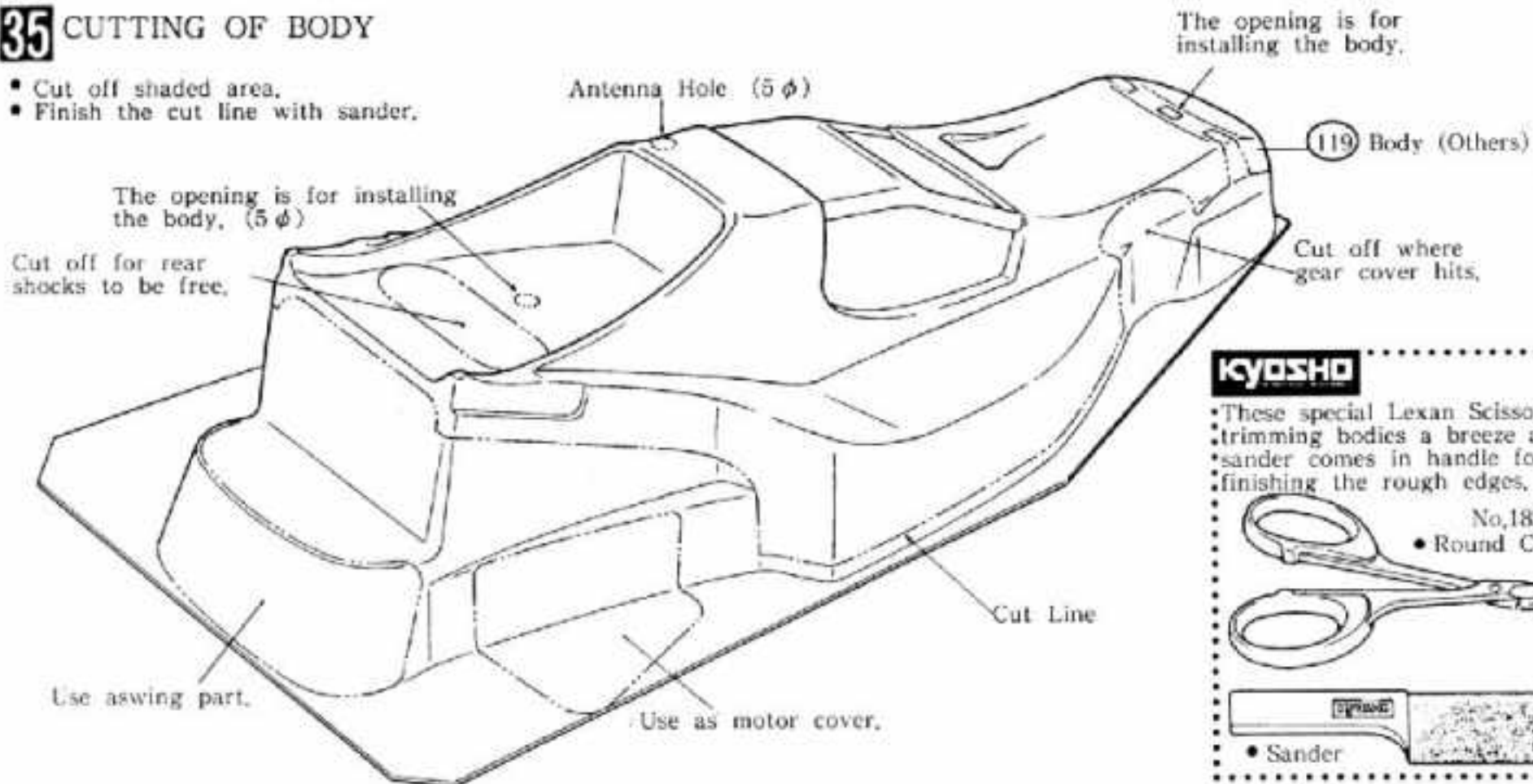

**KYOSHO**

• These special Lexan Scissors make trimming bodies a breeze and the sander comes in handy for finishing the rough edges.

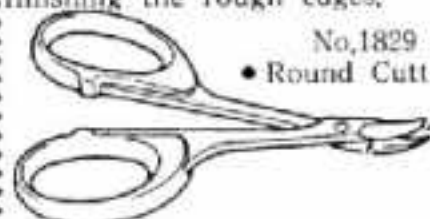

No.1829

- Round Cut



- Sander

**36** PAINTING

1. Before painting, wash the body with neutral detergent to remove any oil or dirt and rinse thoroughly with clean water.
2. You can obtain a color scheme by masking a portion with tape then removing the tape and painting.
3. Paint the inside of the body to produce a smooth looking outer finish.
4. Use your darker colors first then the lighter colors. This will prevent the darker colors from bleeding through the lighter colors.

Make the windows with the micron tape and paint the body in any color you like.

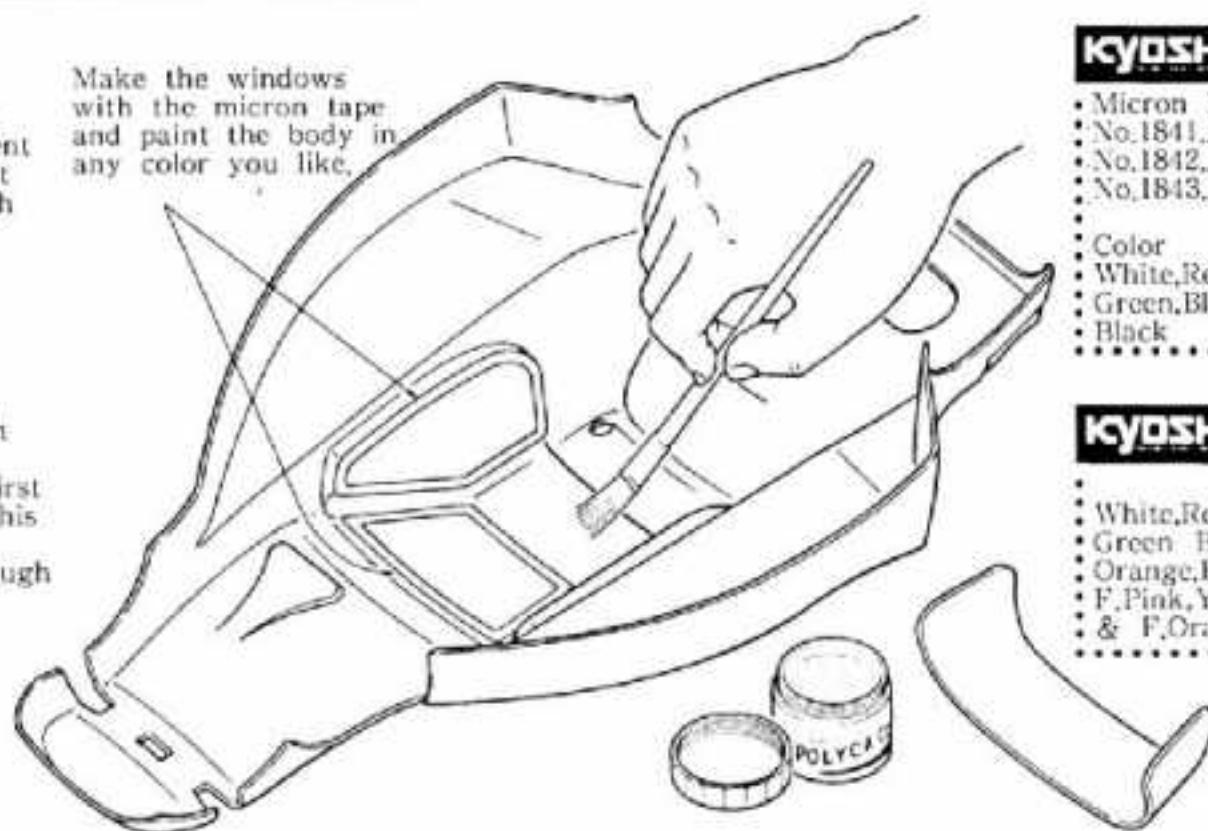

**KYOSHO**

- Micron Line Tape
- No.1841...1,00mm
- No.1842...1,5mm
- No.1843...2,5mm



- Color
- White, Red, Yellow,
- Green, Blue &
- Black

**KYOSHO**

Polica  
Color  
No.2230

- White, Red, Yellow,
- Green, Blue, Sky Blue,
- Orange, Black, Violet,
- F. Pink, Yellow Green & F. Orange.



**37** ASSEMBLY OF BODY AND APPLYING OF DECAL

[Hints for Applying Decal]

Cut off the decals along the cutout line with scissors. Do not apply it abruptly. Convince yourself of the position by trying the decals with the backing paper on. Be careful not to have air bubbles left. Try to smooth out the decal's surface from the center to the periphery. (Particularly be cautious with a large decal.)

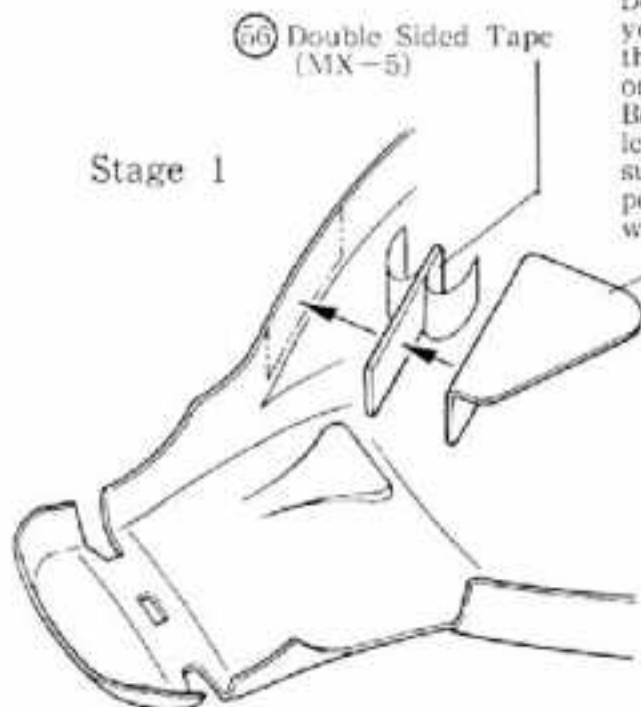

Motor Cover

Stage 2

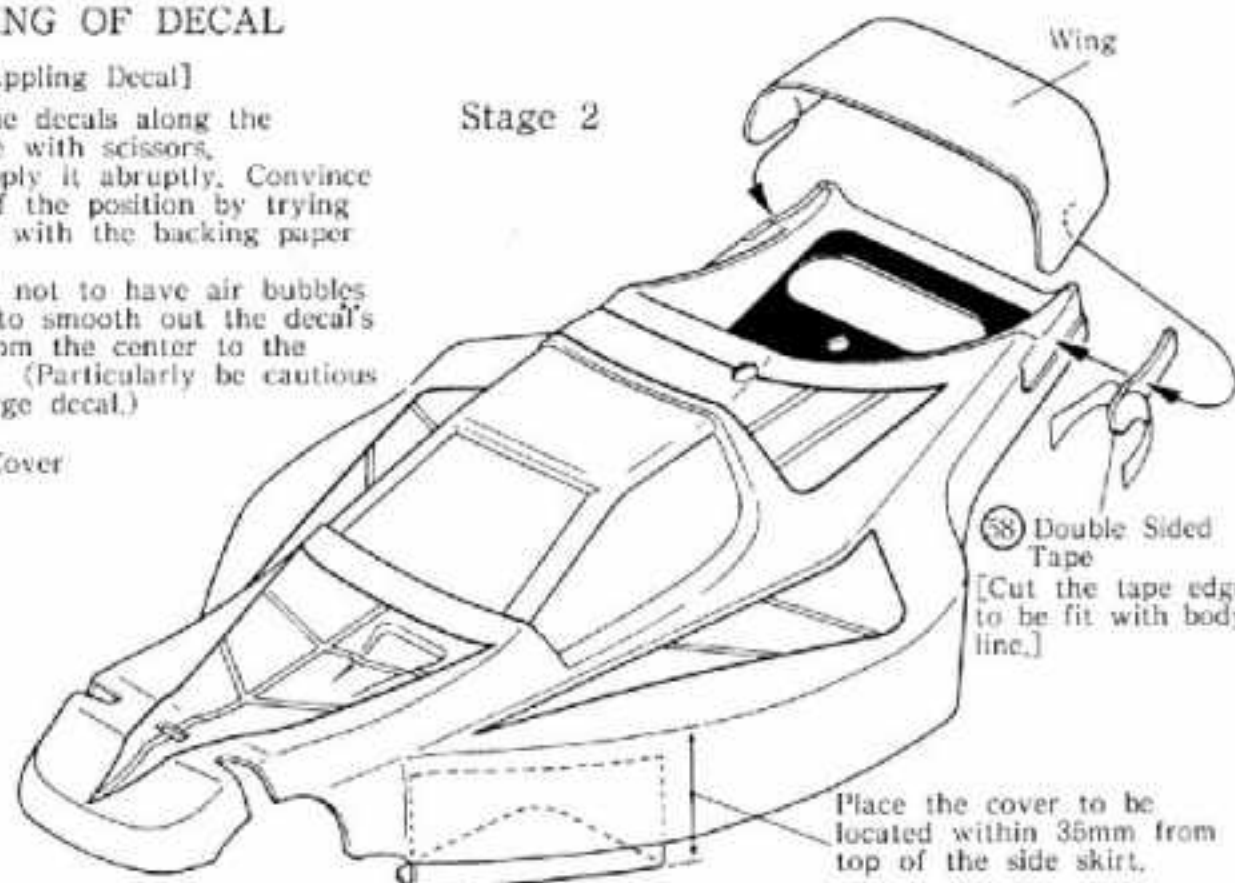

(58) Double Sided Tape

[Cut the tape edge to be fit with body line.]

Place the cover to be located within 35mm from top of the side skirt.

# 38 INSTALLATION OF BODY

127 Body Pins...2  
(MX-1)

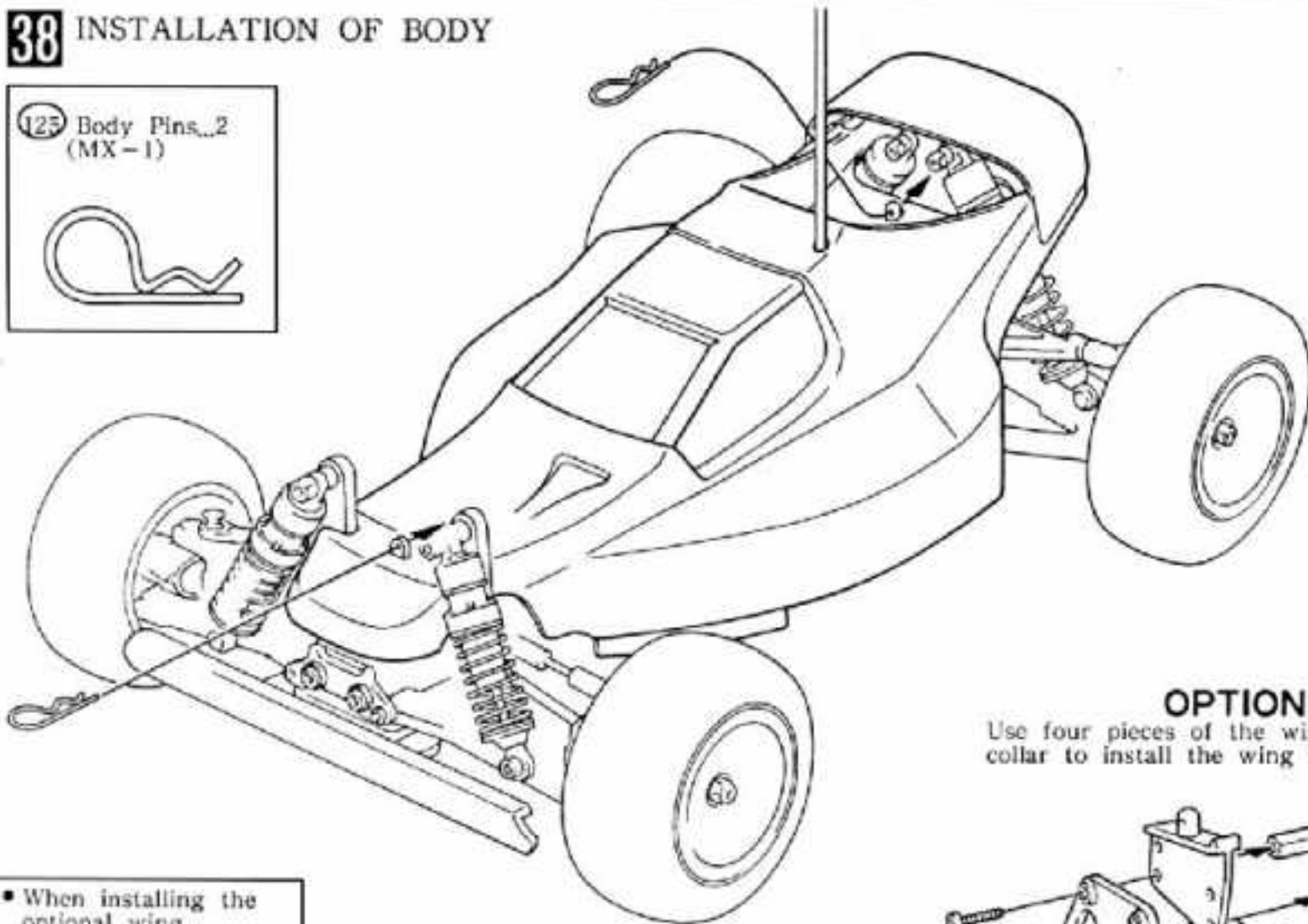

• When installing the optional wing...

M2.6x12  
TP Bind Screws...4

M3x30 Bind Screws...2

98 Wing Collars...4  
(MX-6)

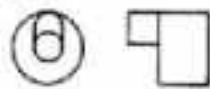

## OPTION

Use four pieces of the wing collar to install the wing stay.

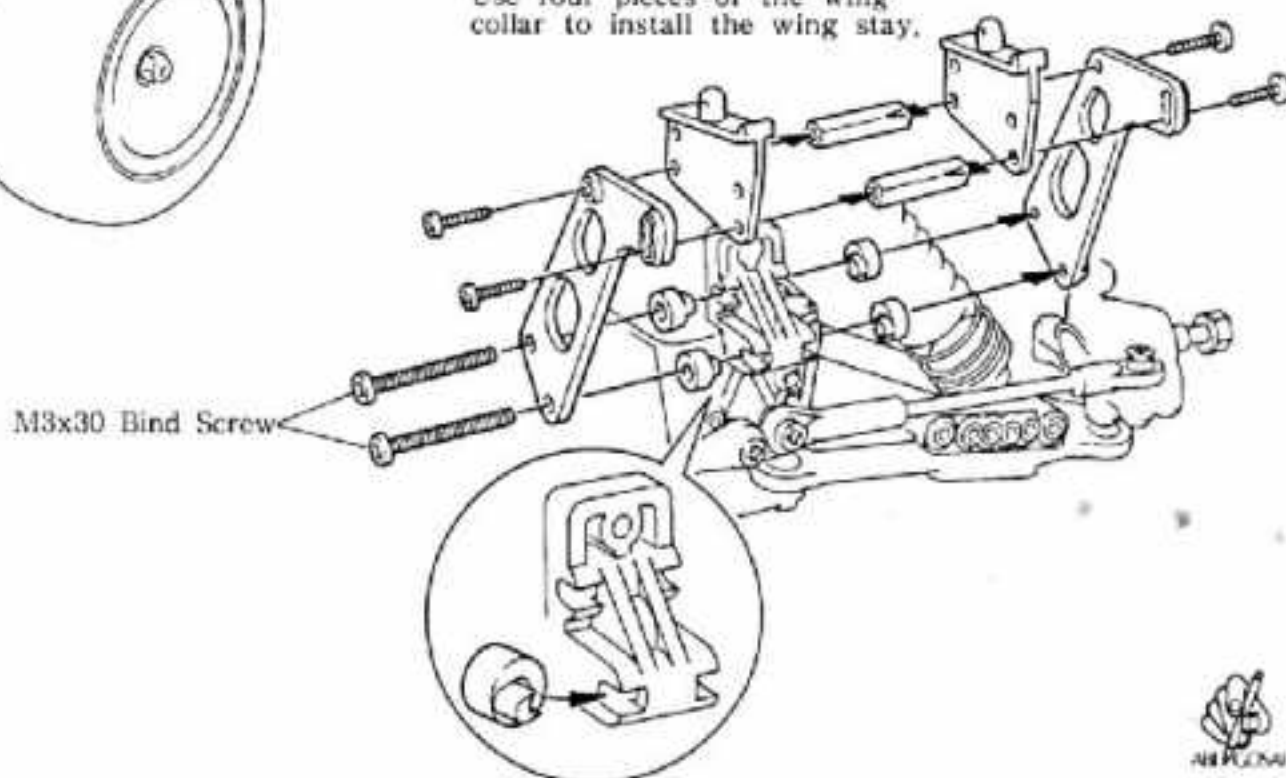

## CHECKING AND MAINTENANCE OF SPEED CONTROLLER

Check the following four points, (1) to (4), before running the Car.

### [Checking Points]

- (1) Check that the center nut and the cord fixing nuts are tightened properly.
- (2) When turning the rotor, the cords will hit the rotor or the center nut and, as a result, will force up a contact.
- (3) Or the cord rubs against the body and pushes up a contact.
- (4) The speed control rod will hit a cord fixing nut.

### [Maintenance]

Remove the center nut once in a while and clean the inside of the controller.

- \* When you notice the uneven running of the motor, check all four checking points (1) to (4) listed above. If you find all in good condition, (In this case, the surface of the controller plate must be worn away considerably.)

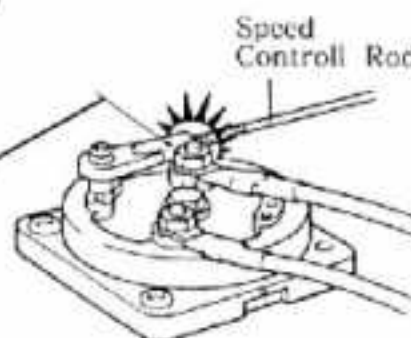
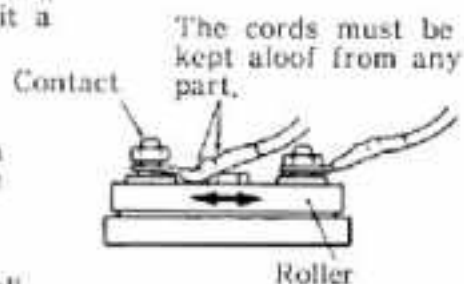
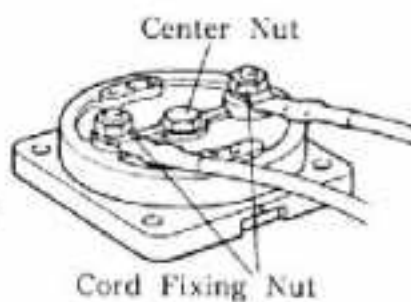

The cords must be kept aloof from any part.

## SETTING GUIDE (1)

Adjust the right and left shocks in such a way that both sides of the front wheel will touch down the ground simultaneously when raising the front portion of the model and lowering it down gently. In the case the right and left side wheels does not land at same time, the steering of each wheel will differ.

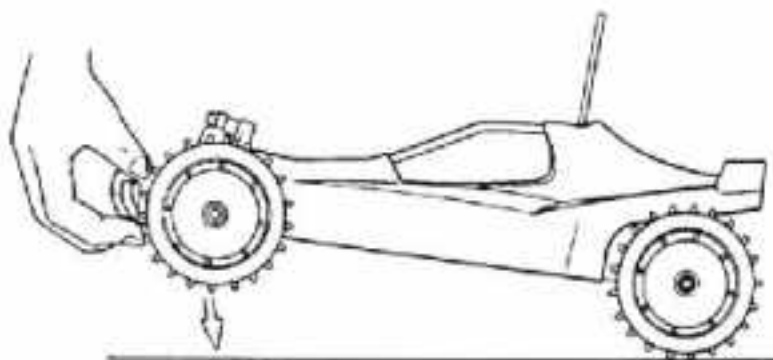

Adjust it longer    Make it shorter    Adjust it shorter    Make it longer.

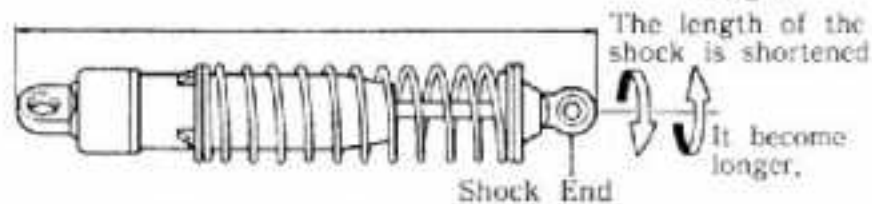

Turn the shock end in or out for the adjustment.

## SETTING GUIDE (2)

### Adjustment of Suspension Spring

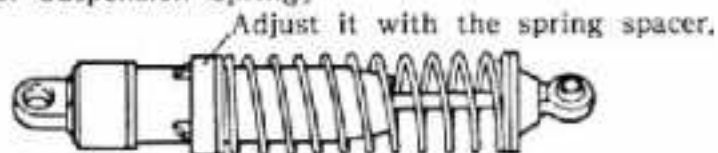

### [Adjustment of Hardness of Shock Action]

\*Take the chart just as general indication.

No.1951 Oil Set	Yellow	Green	Yellow	Red	Green	Red
Piston						
Hardness	← Harder			Softer →		

### [Adjustment of Shock Oil and Spring]

Front ( With lighter shock oil ) → Quicker steering response  
 ( With less spring tension )

Front ( With heavier shock oil ) → Slower steering response  
 ( With more spring tension )

Rear ( With lighter shock oil ) → More traction  
 ( With less spring tension )

Rear ( With heavier shock oil ) → Less traction  
 ( With more spring tension )

### [Gear Ratios and Optional Motors]

Pinion Geare	14	15	16	17	18	19	20
Gear Ratio	8.8	8.2	7.7	7.3	6.9	6.5	6.2
Proper Motor	Le Mans Speed 240T SPA 240WS						
	Le Mans 240ST, H240S						
					Le Mans 360GOLD		

### [Adjustment of Car Clearance]

#### (1) Adjustment of Front Clearance

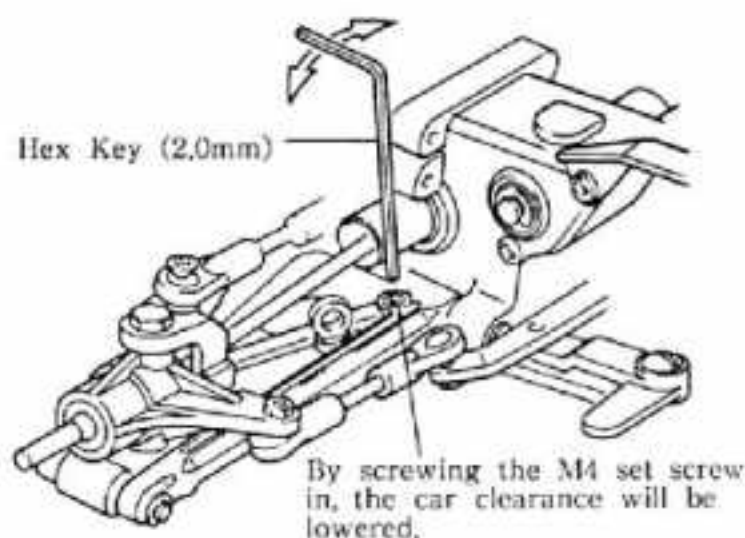

#### (2) Adjustment of Rear Clearance

You can adjust it by shifting the connecting point of the rear shock end to the rear shock stay (B).

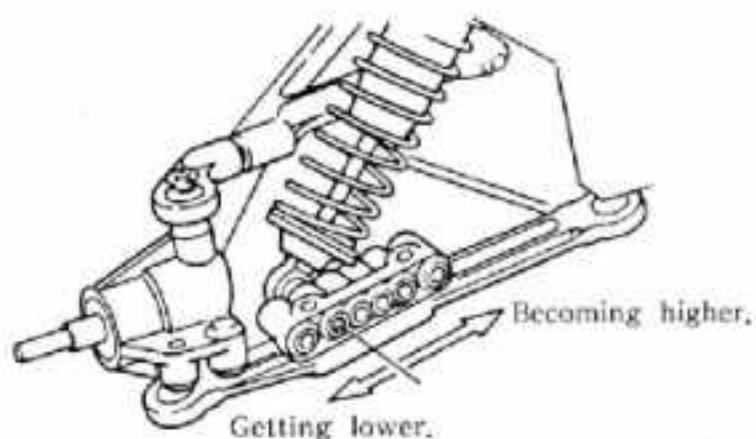

\*As illustrated above, you can adjust the car clearance. The general idea is to have a low clearance on a good tractional road like a shortly moved lawn, and to set it high on a slippery road.

## PARTS LIST

Key #	Parts Name	Q'ty	Key #	Parts Name	Q'ty	Key #	Parts Name	Q'ty	Key #	Parts Name	Q'ty
①	Main Chassis	1	⑬	Rear Wheel Shaft	2	⑤	Front Suspension Arm	2	⑩	Resistor Mount	1
②	Knuckle Arm (R)	1	⑭	Arm Bush (A)	2	⑥	Gearbox (R)	1	⑪	Wing Collar	4
③	Knuckle Arm (L)	1	⑮	Arm Bus (B)	2	⑦	Gearbox (L)	1	⑫	Bulk Head	1
④	Center Gear	1	⑯	King Pin	4	⑧	Rear Suspension Arm (A)	2	⑬	Servo Stay (B)	1
⑤	Counter Gear	1	⑰	2 φ x 11 Pin	4	⑨	Rear Suspension Arm (B)	2	⑭	Humper	1
⑥	Final Pinion	1	⑱	Center Gear Shaft	1	⑩	Suspension Arm Bracket	2	⑮	Bumper Arm	1
⑦	Pinion Gear (15T)	1	⑲	Counter Gear Shaft	1	⑪	Rear Shock (B)	2	⑯	Upper Deck Mount	1
⑧	Front Drive Washer	2	⑳	Bevel Shaft	1	⑫	Sus Arm End	2	⑰	Linkage Collar	2
⑨	Joint	2	㉑	Bevel Gear (A)	2	⑬	5.8 φ Ball End (M)	2	⑱	Suspension Shaft (Short)	2
⑩	Le Mans 240ST Motor	1	㉒	Bevel Gear (B)	2	⑭	5.8 φ Ball End (L)	2	⑲	Suspension Shaft (Medium)	2
⑪	Swing Shaft	2	㉓	Main Gear	1	⑮	Rear Hub	2	⑳	Suspension Shaft (Long)	2
⑫	Front Wheel Shaft	2	㉔	Differential Gear	1	⑯	Servo Mount	2	㉑	Front Tie Rod	2
⑬	Rotary Speed Controller	1	㉕	O Ring (P3)	1	⑰	Joint Arm (A)	1	㉒	Upper Rod	2
⑭	Resistor	1	㉖	8 φ Plain Bearing	2	⑱	Joint Arm (B)	1	㉓	Rear Tie Rod	2
⑮	Resistor Cover	1	㉗	4 φ x 8 Plain Bearing	1	⑳	Saver Washer	1	㉔	5.8 φ Ball End (S)	8
⑯	Motor Plate	1	㉘	5 φ x 10 Plain Bearing	10	㉕	Speed Controller Arm	1	㉕	4.8 φ Ball End	1
⑰	Front Shock Spring	1	㉙	10 φ x 14 Plain Bearing	2	㉖	Shock Bush	4	㉖	M2.6 Pillow Ball (Black)	6
⑱	Rear Shock Spring	1	㉚	Tie Rod Joint	1	㉗	Servo Stay (A)	2	㉗	Pivot	2
⑲	Front Shock Case	2	㉛	Torque Rod	1	㉘	M4 Plastic Nut	4	㉘	6.8 φ Ball	6
⑳	Front Shock Shaft	2	㉜	Suspension Plate	1	㉙	M3 Plastic Nut	6	㉙	5.8 φ Ball	10
㉑	Pressure Top	4	㉝	Upper Deck	1	㉚	Shock Spacer	4	㉚	4.8 φ Ball	1
㉒	Shock Ring	4	㉞	Steering Rod	1	㉛	Servo Saver	1	㉛	Battery Holder	2
㉓	E Ring (E2.5)	18	㉟	Speed Controller Rod	1	㉜	Saver Ring	1	㉜	Body	1
㉔	Shock End	4	㊱	Gear Cover	1	㉝	Saver Horn (F)	1	㉝	Tire	4
㉕	Spring Spacer	4	㊲	Motor Cord	1 set	㉞	Saver Horn (LS)	1	㉞	Decal	1
㉖	Spring Holder	4	㊳	Double Sided Tape	1	㉟	Saver Horn (SS)	1	㉟	E Ring (E3) (Black)	2
㉗	Shock Cap	4	㊴	Strap (S)	3	㊱	Gearbox Hatch	1	㊱	E Ring (E4)	2
㉘	Shock Piston	4	㊵	Ni-Cad Strap	2	㊲	Rear Drive Washer	2	㊲	Hook Pin	1
㉙	Rear Shock Case	2	㊶	Antenna Pipe	1	㊳	Front Shock Stay	1	㊳	Body Pin	2
㉚	Rear Shock Shaft	2	㊷	Resistor Bracket	1	㊴	Rear Shock Stay (A)	1	㊴	Condenser	1
㉛	Shock Oil (Green)	1	㊸	Front Hub	2	㊵	Body Mount	1			
㉜	Wheel	4	㊹	Stabilizer End	2	㊶	Switch Holder	1			

## PURCHASABLE PARTS FOR YOUR KIT

You can purchase replacement optional parts for your kit. All of the part identified by key number are usually not available singularly, but we offer these parts in convenient parts "packs" which can be purchased separately. To figure out which parts pack you need, find the key number for that part which the manual.

Then consult out part pack guide below. When referring to the parts you need, always use the Parts Pack Number. For example, if you need a Center Gear (Key #4) ask your dealer for Kyosho Part Pack UM-1 (Gear Set).

No.	Parts Name	Key No. & Q'ty
MA-1	Bumper Set	④④④④④④④④×1 ④×4
MA-2	Front Sus. Arm Set	④④④×2
MA-3	Rear Sus. Arm Set	④④④④④④④④×2
MA-4	Gearbox Set	④④×1
MA-5	Servo Saver Set	④④④④④④④④④×1 ④④④×4 ④④×2 ④×6
MA-6	Shock Stay Set	④④④×1
MA-7	Motor Plate	④④×1
MA-8	Main Chassis	①×1
MA-9	Tie Rod Plate	④④④×1
MA-10	Upper Deck	④×1 ④×2
MA-11	Torque Rod Set	④④×1
MA-12	Rear Shaft	④④×2
MA-13	Linkage Set	④④④④④×1 ④×2
MA-14	Body (Maxxum)	④×1
MA-15	Decal	④×1
MA-16	Sus. Shaft Set	④④④④×2
MA-17	Wheel Set	④×4
MA-18	Screw Set	Screw, Nut Set
OT-39	E Ring (E2.5)	④×10
CB-72	E Ring (E3)	④×4
KC-20	E Ring (E4)	④×4
1B15	Rotary Speed Controller	④×1
1B17	Resistor Set 15W	④④④×1
EP-22	Hook Pin	④×5
1B89	Body Pin	④×5
UM-1	Gear Set	④④④④×1
UM-5	Gear Shaft Set	④×2 ④④×1
FD-37	Black Shock (S)	④④④④④④④④④×2 ④×4
FD-38	Black Shock (L)	④④④④④④④④④×2 ④×4
OT-4	King Pin	④×4
OT-5	Joint	④×2
OT-6	Swing Shaft	④×2
OT-16	Knuckle Arm	④④×1
OT-17	Front Shaft	④×2
OT-19	Drive Washer	④×4
OT-24	Pinion Gear (15T)	④×1
OT-28	Differential Set	④×2 ④④×4
OT-29	O Ring	④×10
OT-32	5.8 φ Ball	④×10
OT-35	Upper Rod Set	④④×2 ④×8
OT-36	2.6 Pillow Ball	④×10
OT-38	Silicon Grease	2 pcs.
OT-66	Low Profile Tire	④×2
OT-79	Motor Cord	④ 1 Set
BS-46	6.8 φ Ball	④×10
1B40	Double Sided Tape	④×1
1B78	Screw Cement (Duckite)	2 pcs.
1914	4 φ x8 Plain Bearing	④×10

No.	Parts Name	Key No. & Q'ty
1916	5 φ X10 Plain Bearing	④×10
1918	8 φ X14 Plain Bearing	④④×10
SC-89	Tie Rod Set	④×2
SD-79	Antenna Pipe	④×5
EF-37	Strap (S)	④×6
EF-39	Ni-Cd Strap	④×6

### Optional Parts

MAW-1	Stabilizer	Front, Rear Stabilizer Set
OT-75	Hard Final Pinion	Gear need flat surface on the shaft
LM-18	Maintenance Kit	Maintenance parts for motor and 12b.
1951	Shock Oil Set (S,M,H)	Soft, Midium, Hard
1953	Silicon Oil (S)	Viscosity 100SC, 200SC x 1 (Same as 1951S)
1954	Silicon Oil (M)	Viscosity 300SC, 400SC x 1 (Same as 1951M)
1955	Silicon Oil (H)	Viscosity 500SC, 600SC x 1 (Same as 1951H)
W-5003	Adjustable Shock (S)	Easy adjusting
W-5004	Adjustable Shock (L)	•
W-5021	Low Profile Wheel	Silver Plate x 2
W-5022	Narrow Wheel	• •
W-5032	Low Profil Tire Soft	Soft Dirt Tire x 2
OT-51	Pinion Gear (14T)	1 pc.
OT-52	• (16T)	•
OT-53	• (17T)	•
UM-23	• (18T)	•
UM-24	• (19T)	•
UM-25	• (20T)	•
EF-103	Racing Wire	4 φ Silicon Cord
LM-15	Motor cooling Plate	Cooling Plate (For Le Man)
1901	Ball Bearing (5 φ x10)	Exchange 48 plate bearing 2pcs.
1903	• (4 φ x8)	④ • •
1911	• (8 φ x14)	④④ • •
1B71	Sponge Tire (A)	Wet-hard Surface Type
1B83	Frontier Hobby Oil	30cc
1B63	Sponsor Sticker	Decal Sponser Mark
1945	Oil Spray	Spray Type Oil
W-5001	Pressure Shock (S)	Made with high quality
W-5002	• (L)	•
W-5005	Special Rod Set	Front Upper Arm, Front Tie Rod, Rear Rod One touch Adjustment
W-5061	Universal Swing Shaft	11,12 one piece made
W-5031	Low Profile Tire (Hard)	2 pcs.
W-0109	Ball Differential	Adjustable Differential
W-0110	Special Spur Gear	Use as set, Future of taking fine gear Ratio
W-5085 W-5095	Hard Pinion Gear (15T - 25T)	
W-0111	Special Counter Gear	Reinforced type for ⑤

# MAXXUM FF

## EXPLODED VIEW

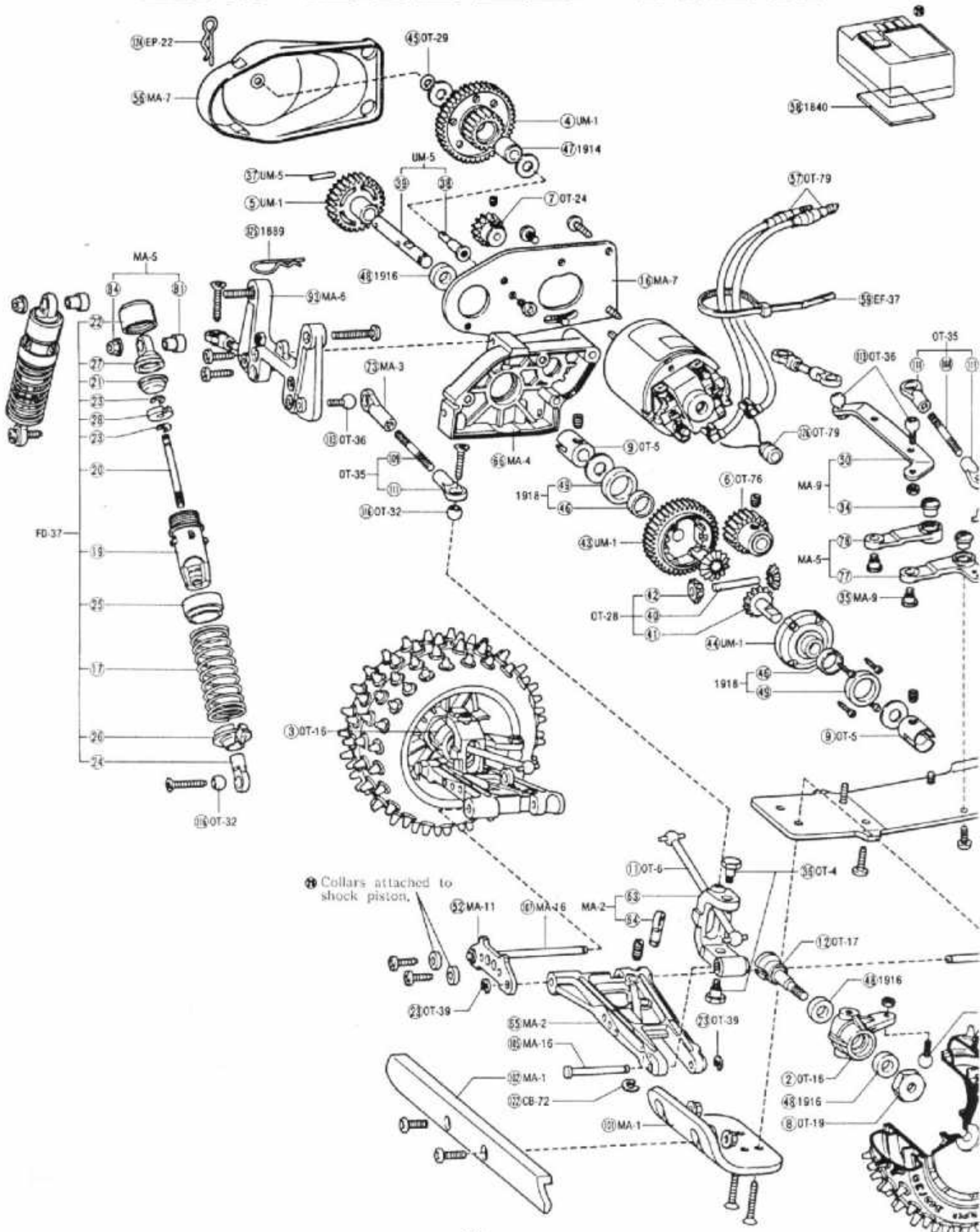



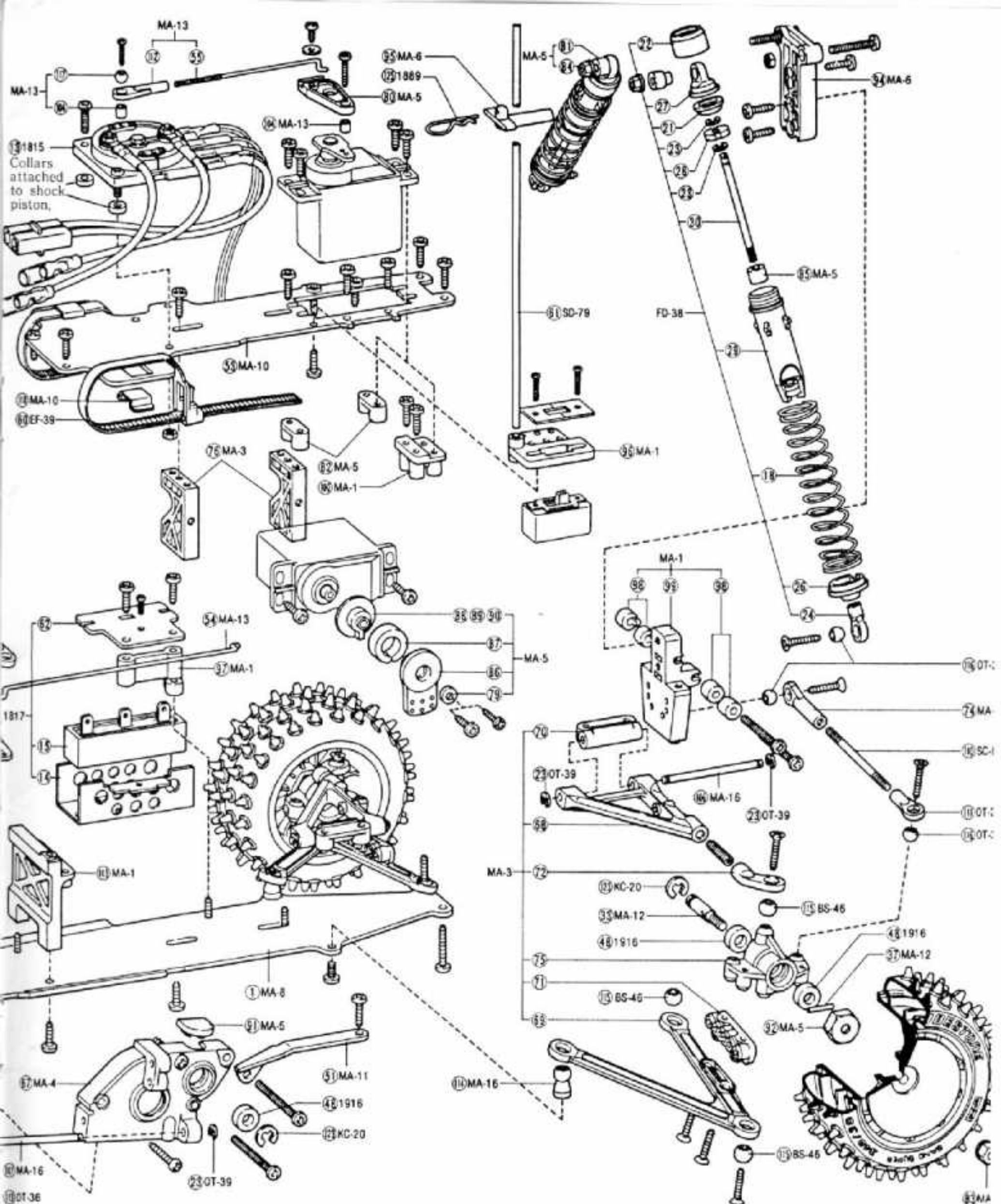

Attention: 61 is used when option front stabilizer is used, 98 is used when option wing is installed 100 is used when mini servo must be installed.

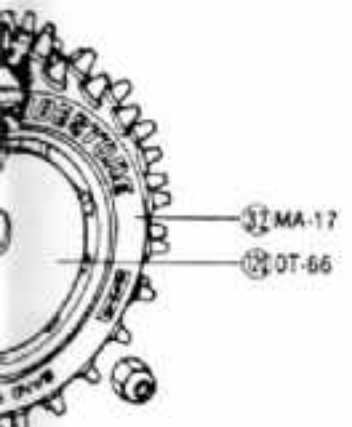

—The Super Hobby—  
**KYOSHO**  
 KYOSHO CORPORATION

---

*The Super Hobby*

**KYOSHO**®  
THE FINEST RADIO CONTROL MODELS

\*This products is not to be sold in the United States. If you have purchased this product in the United States, please contact Tom Miller at Kyosho U.S.A. phone number (217) 398-3630.\*

---

PRINTED IN JAPAN

AFCL5T